

■ Pickups & Trigger Drives

Why do you want to become an Artist?

The common Practice in the Industry has Called for Filing your own Trigger Reluctor Pin

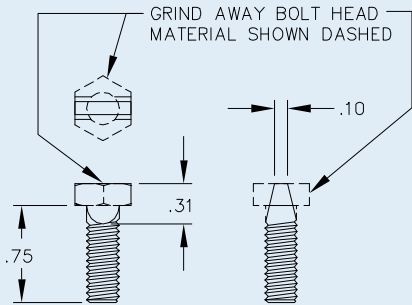

FABRICATE RESET PIN USING 1/4-20 X 3/4 INCH LONG FERROUS HEX BOLT TO DIMENSIONS SHOWN.

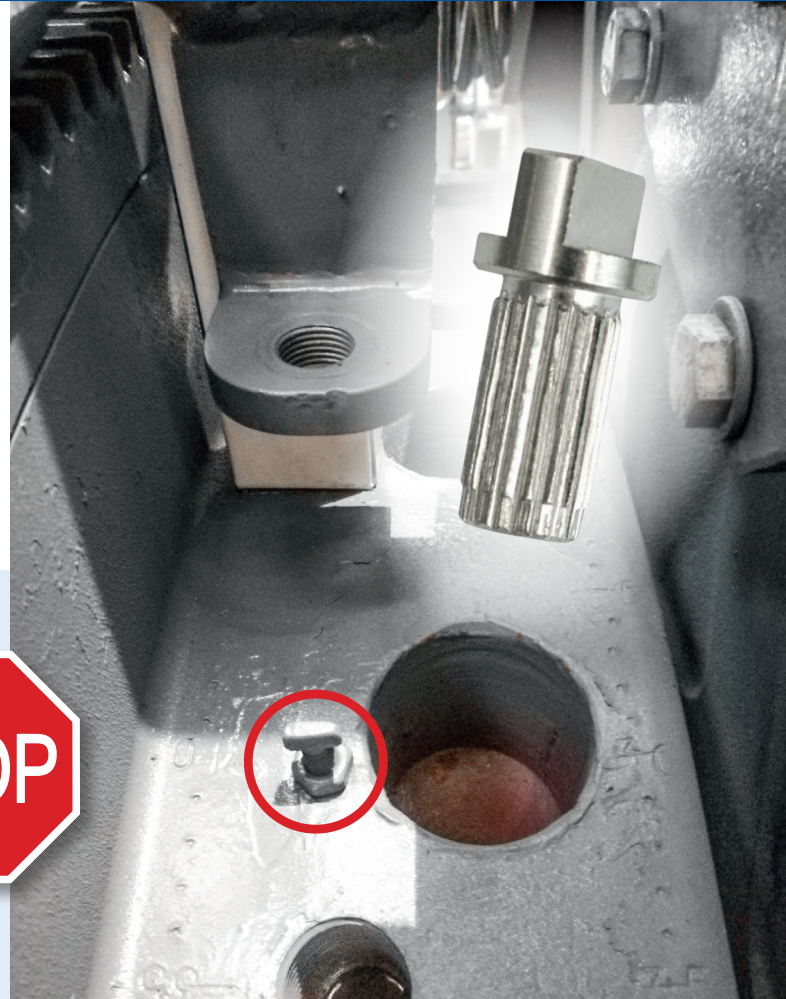

MOTORTECH for years supplies pre-made trigger reluctor pins which are easy to install:

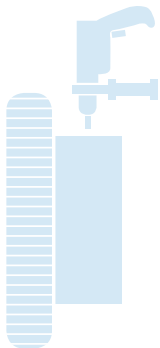

1 Drill the hole
(Ø 1/4 in / 6.4 mm)



2 Orientate the trigger reluctor pin P/N 06.80.104 so the top trigger flat is square

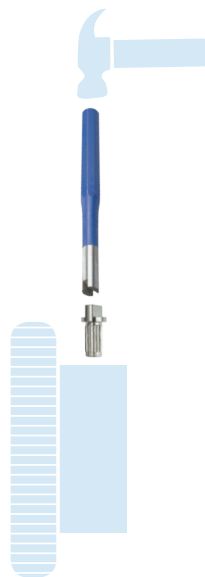

3 Take the installation tool P/N 44.99.011, insert the trigger reluctor pin P/N 06.80.104 into the hole and punch it into flywheel.

Done!

You will have perfect edges to initiate the trigger signal