

■ Spark Plugs & Accessories

MPC1900

MOTORTECH Pre-Chamber Spark Plug

MOTORTECH's MPC1900 pre-chamber spark plug is a cost-effective high performance solution for a wide variety of stationary gas engines. It features a rigid design for industrial purposes that guarantees a long service life. The innovative product optimizes combustion in the engine and improves efficiency and emission values.

- Made in Germany
- Iridium/Platinum alloy on center and ground electrode
- Resistant high quality ceramics made for best mechanical, thermal and electrical properties
- Laser technology makes a perfect alloy at the seam possible
- Hot locking technology guarantees high durability in high compression engines
- Monolithic resistor
- High quality steel shell, nickel-plated for excellent corrosion resistance



MPC1900

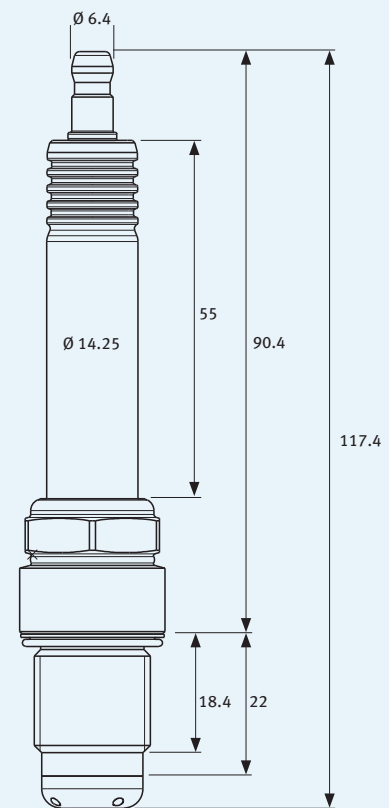

Call MOTORTECH or your nearest MOTORTECH sales partner for information about the range of application.

Thread Size:	M18x1.5
Thread Reach:	22.0 mm
Alloy Center/ Ground Electrode:	Iridium / Platinum (Ir/Pt)
HEX:	20.8 mm / 13/16 in.
Spark Plug Socket:	07.99.022-4-L
Tightening Torque:	50 to 60 Nm / 37 to 44 lb-ft