

■ Spark Plugs & Accessories

MOTORTECH Extended Barrel Spark Plugs For CAMDA® Gensets

Especially for CAMDA® gensets with CUMMINS® 6 and 12 cylinder engines, MOTORTECH offers improved spark plugs based on its XTL and XT-Plug design. The XT-Plug version with its 3/4 inch male thread replaces commonly used spark plugs and is used for connection with an Unshielded Safety Lead. The XTL-Plug is manufactured with an integrated spark plug lead, which allows a direct connection to an externally mounted ignition coil and use of diagnostic tools like a high voltage clamp or Scope Meter.

To achieve an increase in reliability and runtimes, MOTORTECH uses a J-type base spark plug with Iridium and Platinum alloy on center and ground electrode. The M14x1.25 thread with an extended reach of 26.5 mm perfectly fits the application.

Next to the mentioned features, MOTORTECH's XTL and XT-Plug design eliminates several of the known problems of products made by competitors.

- | | |
|--|--|
| <p>A Integrated 7 mm spark plug lead for a direct connection to an ignition coil</p> <p>B 3/4 inch male thread for connection of Unshielded Safety Leads</p> <p>C Built in ceramics with 2 inch terminal well depth for best flashover protection</p> | <p>D 13 in. extended barrel length</p> <p>E M14x1.25 thread size with long 26.5 mm reach</p> <p>F J-type design with iridium alloy center electrode and platinum ground electrode</p> |
|--|--|



Features

- No more trapped air in the extension barrel
- No more condensation
- No internal flashover
- Built in ceramics
- High dielectric strength
- Rigid welds

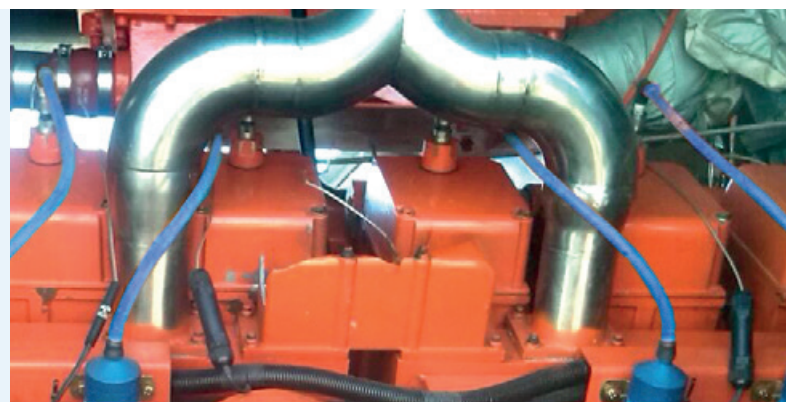

Spark Plugs & Accessories

Technical Data & Dimensions

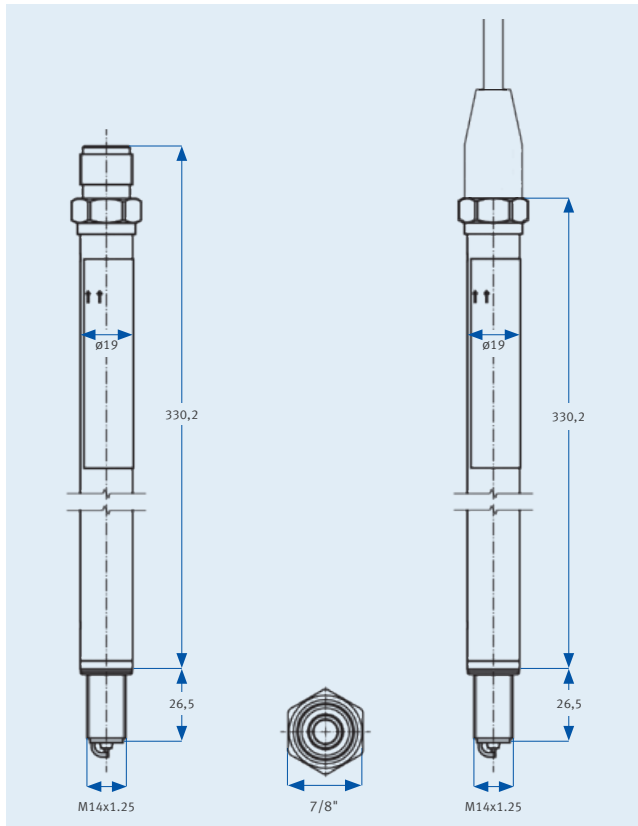

Thread size: M14x1.25
 Thread reach: 26.5 mm (1.050 inch)
 Electrode design: J-Type – Ir/Pt
 HEX: 7/8 inch
 Tightening torque: 22 Nm (16 lb-ft)
 Electrode gap: 0.30 mm (0.012 inch)

Ordering Information

P/N	Description	Equivalent to
D462BEX13-B201	XTL-Plug, M14x1.25, 13 inch barrel length, 20 inch lead length	
S2D462BEX13	XT-Plug, M14x1.25, 13 inch barrel length	S-RSGN40XL-2

Additional Equipment



Unshielded Safety Lead
 P/N 09.02.4001-20



Ignition Coil
 P/N 06.50.055



SparkView High Voltage Indicator
 P/N 06.50.099-100



Spark Plug Cleaning Kit
 P/N 44.01.023

Ordering Information – Additional Equipment

P/N	Description	Equivalent to
09.02.4001-20	Unshielded safety lead, 20 inch length	USL2LE-20A
06.50.055	Ignition coil	501061
06.90.099-100	SparkView high voltage indicator incl. SparkScan1 high voltage clamp	
44.01.023	Spark plug cleaning kit	