

Product Information



MPC1900 MOTORTECH Pre-Chamber Spark Plug

Design Change as of October 2019

From October 2019, the MOTORTECH MPC1900 pre-chamber spark plug will be delivered with a newly designed ceramic insulator.

Compared to the current version, the ceramic insulator will be shortened by 3 mm and will no longer be equipped with creepage current barriers in the future. The other properties of the spark plug, such as thread size and reach, alloy of center and ground electrode, electrode gap and hex remain unchanged.

Ordering Information

P/N	Description	Equivalent to
MPC1900	Pre-chamber spark plug, M18x1.5, thread reach 18.4 mm (0.724 in), Ir/Pt, electrode gap 0.35 mm (0.014 in), HEX 20.8 mm (13/16 in)	18VGZ1-77, FB95WPV, MPC1800, X52404500049, X52404500039, X52404500027

Further information on the pre-chamber spark plug MPC1900 is available for download at

<https://www.motortech.de/infocenter/download-center/sales-flyer.html>.



DISTRIBUTION

Customers / others	Yes
Representatives and Sales Partners	Yes
OEM partners	Yes
MOTORTECH subsidiaries	Yes

Product Information

MPC1900 (C) – As of October 2019

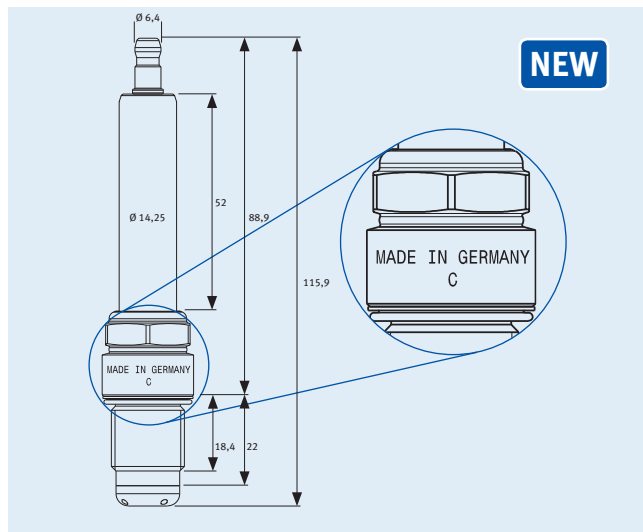

MPC1900 (B) – Old spark plug

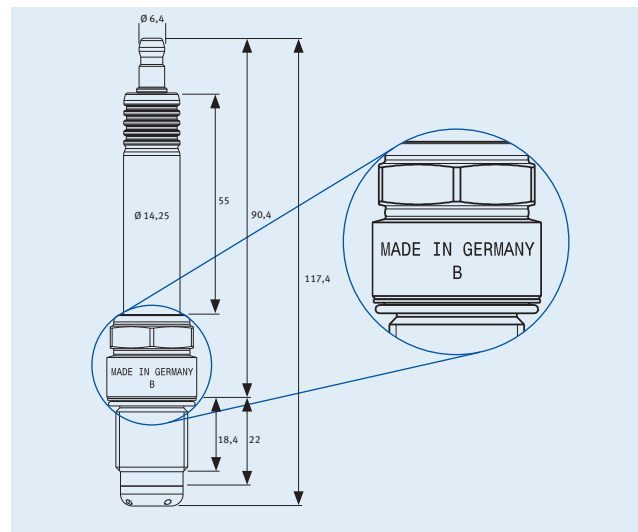

MOTORTECH GmbH
 Hogrevestr. 21-23
 29223 Celle, Germany
 Phone: +49 5141 - 93 99 0
 Fax: +49 5141 - 93 99 99
 www.motortech.de
 motortech@motortech.de

MOTORTECH AMERICAS, LLC
 1400 Dealers Avenue, Suite A
 New Orleans, LA 70123
 Phone: +1 504 355 4212
 Fax: +1 504 355 4217
 www.motortechamericas.com
 info@motortechamericas.com

DISTRIBUTION

Customers / others	Yes
Representatives and Sales Partners	Yes
OEM partners	Yes
MOTORTECH subsidiaries	Yes