



NO_x Sensor

P/N 56.03.005

Installation Instruction



Original installation instruction

© Copyright 2025 MOTORTECH GmbH. All rights reserved.

MOTORTECH products and the MOTORTECH logo are registered and/or common law trademarks of the MOTORTECH GmbH. All further trademarks and logos displayed or used in this publication are the property of the respective entitled person and are used for reference purposes only.

Information contained in this publication may be changed without prior notice.

1 General Information	5
1.1 What Is the Purpose of this Installation Instruction?.....	5
1.2 Who Is this Installation Instruction Targeted To?	5
1.3 What Symbols Are Used in the Installation Instruction?.....	5
1.4 Which Abbreviations/Acronyms Are Used in the Installation Instruction?	6
2 Safety Instructions	7
2.1 General Safety Instructions	7
2.2 Electrostatic Discharge Hazards.....	8
2.3 Special Safety Instructions for the Device.....	8
2.4 Proper Storage	11
2.5 Proper Transport.....	11
2.6 Proper Disposal.....	11
3 Intended Use	12
3.1 Functional Description.....	12
3.2 Applications	12
4 Product Description	13
4.1 Technical Data	13
4.1.1 Certifications.....	13
4.1.2 Mechanical Data	13
4.1.3 Warning Notices on the Device	14
4.1.4 Product Identification – Labeling on the Device.....	14
4.1.5 Electrical Data	14
4.1.6 Interfaces	15
4.1.7 Overview Drawings	16
5 Functions	17
5.1 Output of Measured Values	17
5.2 Heating Modes.....	17
5.3 Readable Correction Factors	17
5.4 Automatic Bit Rate Detection in CAN Bus.....	17
6 Installation Instructions	18
6.1 Preparation	18
6.1.1 Mounting Position of Sensing Element	18
6.1.2 Mounting Position of Evaluation Unit	19
6.1.3 Laying the Connection Cable	20
6.1.4 External Power Supply	20
6.2 Unpacking	20
6.3 Material Needed	21
6.4 Mounting.....	21
6.5 Wiring	24
6.6 Setting CAN Identifier.....	24
6.7 Setting up Master Control	25
6.8 Dismounting	25
7 Errors	27
7.1 Error Detection.....	27

Table of Contents

7.2 Self-Diagnosis	27
7.3 Customer Service Information.....	27
7.4 Returning Equipment for Repair/Inspection.....	27
7.5 Instructions for Packaging the Equipment	27
8 Maintenance	28
8.1 Cleaning the NO _x Sensor	28
8.2 Spare Parts and Accessories	28

Prior to use, read this installation instruction carefully and familiarize yourself with the product. Installation and start-up should not be carried out before reading and understanding this document. Keep this installation instruction readily available so that you can reference it as needed.

1.1 What Is the Purpose of this Installation Instruction?

This installation instruction serves as an aid for the installation of the product and supports the technical staff with all maintenance tasks to be performed. Furthermore, this instruction is aimed at preventing dangers to life and health of the user and third parties.

1.2 Who Is this Installation Instruction Targeted To?

This installation instruction provides a code of conduct for personnel tasked with the setup, operation, maintenance, and repair of gas engines. A certain level of technical knowledge with respect to the operation of gas engines and basic knowledge of the electronic components used are necessary. Persons who are only authorized to operate the gas engine shall be trained by the operating company and shall be expressly instructed concerning potential hazards.

1.3 What Symbols Are Used in the Installation Instruction?

The following symbols are used in this instruction and must be observed:



Example

This symbol indicates examples, which point out necessary action steps and techniques. In addition, you receive additional information from the examples, which will increase your knowledge.

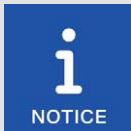

Notice

This symbol indicates important notices for the user. Follow these. In addition, this symbol is used for overviews that give you a summary of the necessary work steps.



Warning

This symbol indicates warnings for possible risks of property damage or risks to health. Read these warning notices carefully and take the mentioned precautionary measures.

1 General Information



Danger

This symbol indicates warnings for danger to life, especially due to high voltage. Read these warning notices carefully and take the mentioned precautionary measures.

1.4 Which Abbreviations/Acronyms Are Used in the Installation Instruction?

The following abbreviations/acronyms are used in the installation instruction.

Abb.	Term	Description	Explanation
CAN bus	Controller Area Network bus	Bus for control devices/networks	Asynchronous serial connection system for linking control units
DC	Direct Current		
ESD	Electrostatic Discharge		
HB	Horizontal Burning		Flammability class as per UL 94

2.1 General Safety Instructions

MOTORTECH equipment is manufactured as state of the art and therefore safe and reliable to operate. Nevertheless, the equipment can cause risks or damage can occur if the following instructions are not complied with:

- The gas engine must only be operated by trained and authorized personnel.
- Observe all safety instructions of the system and all safety instructions of the system operator.
- Operate the equipment only within the parameters specified in the technical data.
- Use the equipment correctly and for its intended use only.
- Never apply force.
- For all work such as installation, conversion, adaptation, maintenance, and repair, all equipment must be disconnected from the mains and secured against unintentional reactivation.
- Perform only such maintenance and repair work as is described in the installation instruction, and follow the instructions given while working.
- Further work must only be performed by personnel authorized by MOTORTECH. Non-compliance with the instructions will void any guarantee for the proper function of the equipment as well as the responsibility for the validity of the certifications.
- Safety devices must not be dismantled or disabled.
- Avoid all activities that can impair the function of the equipment.
- Operate the equipment only while it is in proper condition.
- Investigate all changes detected while operating the gas engine.
- Ensure compliance with all laws, directives, and regulations applicable to the operation of your system, including such not expressly stated herein.
- If the system is not entirely tight and sealed, gas may escape and result in explosion hazard. The inhalation of gas can also lead to death or severe health damages. Therefore, upon completion of all assembly works, always check the system's tightness.
- Always ensure adequate ventilation of the engine compartment.
- Ensure a safe position at the gas engine.
- There is a risk of burning on hot surfaces. Allow the gas engine to cool down before starting any work.
- Personal protective equipment (PPE), e.g. safety shoes and gloves, must be worn during all work on the gas engine.
- Noise from the system can cause permanent or temporary damage to your hearing. Wear suitable hearing protection at the system.
- Your behavior can reduce possible residual risks to a minimum. Observe responsible handling of the gas engine and the gas-carrying system.

2 Safety Instructions

2.2 Electrostatic Discharge Hazards

Electronic equipment is sensitive to static electricity. To protect these components from damage caused by static electricity, special precautions must be taken to minimize or prevent electrostatic discharge.

Observe these safety precautions while you work with the equipment or in its vicinity.

- Before performing maintenance or repair work, ensure that the static electricity inherent to your body is discharged.
- Do not wear clothing made from synthetic materials to prevent static electricity from building up. Your clothing should therefore be made of cotton or cotton mix materials.
- Keep plastics such as vinyl and Styrofoam materials as far away from the equipment and the work environment as possible.

2.3 Special Safety Instructions for the Device



Explosion hazard! Fire hazard!

When operating the NO_x sensor, there is a risk of explosion and fire as its sensing element heats up significantly during operation. Therefore, it is essential to observe the following:

- Use the NO_x sensor for measurement in non-explosive gas mixtures only. Especially in the event of an engine malfunction, make sure that no unburned gas mixture enters the exhaust pipe.
- At the plant, keep all flammable or ignitable materials away from the sensing element.
- Also comply with all locally applicable explosion protection regulations.



Risk of poisoning!

People at the plant can be poisoned by exhaust gases escaping from the exhaust pipe. To prevent this, the NO_x sensor must be mounted on the exhaust pipe in a gas-tight manner. Therefore, check the welding boss and the locking screw for visible damage before and during mounting.



Risk of burning!

There is a risk of burns when touching the sensing element of the NO_x sensor because the sensing element heats up as soon as the NO_x sensor is live. Therefore, observe the following:

- Install the sensing element on the exhaust pipe at a suitable location so that people at the plant cannot be burned by it, or install an appropriate protection around the sensing element that prevents contact with it.
- The sensing element must have cooled down sufficiently after switching off or disconnecting the power supply before you can touch the sensing element again.



Risk of injury!

The NO_x sensor is designed for operation in circuits with **protected extra-low voltage (PELV)**. The voltages in these circuits must not exceed 50 V AC or 75 V DC. To protect the circuit against overload and short circuits, the supply voltage cable must be secured with a suitable fuse (max. 10 A).



Operational safety!

To prevent short circuits that can cause electric shock and serious damage to the connected equipment, always switch off the power supply to the NO_x sensor before disconnecting its electrical connections.

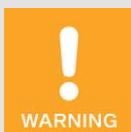

Operational safety!

Proper functioning of the NO_x sensor is only guaranteed if the sensing element does not overheat at the mounting location. Avoid accumulated heat at the sensing element and ensure sufficient ventilation of the sensing element by ambient air.

2 Safety Instructions



Operational safety!

To ensure proper functioning of the NO_x sensor throughout its service life, be sure to observe the following:

- The probe must not come into contact with the following liquids and substances:
 - Condensation water
 - Siloxane substances in volatile, liquid or solid form
 - High amounts of sulfur and phosphorus
 - Other liquid components such as oil and grease
 - Sealants
- Contamination in the exhaust gas, e.g. due to corrosion or material escaping from the catalytic converter, must be avoided.
- The sensor and its electronics must not be painted or otherwise coated.
- Do not open the cover of the evaluation unit's connector.



Operational safety!

The NO_x sensor must not be used any further under any circumstances if it is damaged or the sensing element of the NO_x sensor has been mechanically shocked (e.g. by dropping it on the floor or impacts on the sensing element). In these cases, contact MOTORTECH for sensor replacement (see *Customer Service Information* on page 27).



Operational safety!

Proper functioning of the NO_x sensor is only guaranteed under the following conditions:

- The sensing element may be dismantled and mounted a maximum of five times, provided that its thread is re-greased with one of the recommended greases in the recommended amount as specified in the installation instruction before the sensing element is remounted (see section *Mounting* on page 21).
- The electrical connection to the NO_x sensor's evaluation unit may be disconnected and reestablished a maximum of 5 times.

2.4 Proper Storage

Keep the storage period of the delivered NO_x sensor as short as possible and unpack the NO_x sensor no earlier than directly before mounting (see section *Proper Transport* on page 11). For storage, observe the mechanical specifications of the NO_x sensor (see section *Mechanical Data* on page 13). In the vicinity of the NO_x sensor, no easily evaporating organic materials or silicone-organic materials may be stored.

2.5 Proper Transport

Let the NO_x sensor remain in its original packaging until it reaches its place of use and unpack the NO_x sensor no earlier than directly before mounting.

When carrying the unpacked NO_x sensor, make sure that you do not twist the wires in the connection cable between the sensing element and the evaluation unit. Under any circumstances, do not wrap the connection cable around the evaluation unit. Wrap the connection cable separately from the evaluation unit, and maintain the connection cable's minimum bending radius of 20 mm (0.79") and on both ends of the connection cable the minimum distance of the first bend of 30 mm (1.18").

The protective cap of the sensing element is designed to prevent dirt and dust from entering the sensing element. Do not remove the protective cap from the sensing element until you are instructed to do so within this installation instruction (see section *Mounting* on page 21).

2.6 Proper Disposal

For the proper disposal of MOTORTECH equipment, observe the information provided at www.motortech.de.

3 Intended Use

3.1 Functional Description

The NO_x sensor measures the nitrogen oxide and oxygen concentration in the exhaust gas of stationary gas-powered lean-burn engines in industrial environments and transmits the measured values via the CAN bus to a master control.

For operating the NO_x sensor, a master control is required, which signals the dew point release to the NO_x sensor via the CAN bus.

3.2 Applications

The NO_x sensor is designed for use with stationary gas-powered lean-burn engines in industrial environments whose exhaust gases have an oxygen content ≥ 1 vol%.

The NO_x sensor is suitable for exhaust gases that are free of ammonia and may only be used for measurements in non-explosive gas mixtures.

The NO_x sensor is designed for use in a non-hazardous area.

The NO_x sensor is only suited for measurement when mounted in an exhaust pipe.

As per EN 55011, the NO_x sensor is equipment of Group 1 and Class B.

Any use other than the one described in the installation instruction shall be considered improper use and will result in the voiding of any guarantee.

4.1 Technical Data

4.1.1 Certifications

The NO_x sensor is certified as follows: CE

The EU Declaration of Conformity can be obtained on request from your MOTORTECH contact person (see section *Customer Service Information* on page 27).

4.1.2 Mechanical Data

The NO_x sensor has the following mechanical characteristics:

Feature	Value
Dimensions	Length of probe: 26.4 mm (1.04") Length of sensing element: 85.4 mm (3.37") Evaluation unit (length x width x height): 107.6 mm x 81 mm x 29.1 mm (4.24" x 3.19" x 1.15") Length of connection cable: 985 mm (38.78")
Weight	230 g (0.51 lbs)
Shape of device	See section <i>Overview Drawings</i> on page 16
IP protection rating as per ISO 20653:2013	IP 6K9K with mating plug of same protection rating connected to evaluation unit and sensing element mounted in suitable welding boss from MOTORTECH
Climatic environmental conditions	Operating temperature evaluation unit: –40 °C to +125 °C (–40 °F to +257 °F) Operating temperature hexagon nut: –40 °C to +380 °C (–40 °F to +716 °F) Operating temperature sensing element grommet and connection cable: –40 °C to +210 °C (–40 °F to +410 °F) Storage temperature: –40 °C to +75 °C (–40 °F to +167 °F) 0 % to 60 % humidity without condensation Max. 18 months Exhaust gas temperature range: –40 °C to +850 °C (–40 °F to +1,562 °F) Operating pressure range: 500 mbar abs to 2,000 mbar abs
Flammability class as per UL 94	Evaluation unit: V-0 Bracket: HB
Mounting cycles	Max. 5 when re-greasing sensing element thread after dismounting (see section <i>Mounting</i> on page 21)
Mating cycles evaluation unit	Max. 5
Service life	15,000 operating hours

4 Product Description

4.1.3 Warning Notices on the Device

Information Text on Connector of Evaluation Unit

DO NOT REMOVE

4.1.4 Product Identification – Labeling on the Device

The numbers required for unique product identification are on the top side of the evaluation unit:

- Part number of the NO_x sensor (P/N)
- Serial number of the NO_x sensor (S/N)

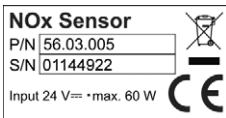

Illustration example

4.1.5 Electrical Data

The NO_x sensor has the following electrical characteristics:

Feature	Value
Power supply	24 V DC (10.7 V DC to 32 V DC)
Maximum power consumption	60 W
Required current	In measuring operation max. 1.4 A _{rms} , 5.7 A _{peak}
Connector evaluation unit	5-pole, connector, Hirschmann, MLK, variant 1, code A

The measuring probe of the NO_x sensor has the following characteristics:

Feature	Value
Measuring range nitrogen oxide (NO _x)	0 ppm to 3,012 ppm
Measurement resolution nitrogen oxide (NO _x)	0.25 ppm
Measuring accuracy nitric oxide (NO)	See table 1, valid measured values from O ₂ ≥ 1 vol%
Response time nitric oxide (NO)	t ₁₀₋₉₀ : <ul style="list-style-type: none">– Max. 2,000 ms at exhaust gas velocity 3 m/s– Max. 1,000 ms at exhaust gas velocity 12 m/s The maximum response time may increase depending on the mounting position and the geometry of the exhaust system.
Light-off time nitric oxide (NO)	Max. 57 s after dew point release at supply voltage 16 V ± 0,2 V
Cross sensitivity NO _x measurement	Ammonia (NH ₃) typ. 115 %
Sensitivity NO _x measurement	Nitrogen dioxide (NO ₂) typ. 82 %

Feature	Value
Measuring range oxygen (O ₂)	0 % to 20.95 %
Measuring accuracy oxygen (O ₂)	See table 2
Response time oxygen (O ₂)	t_{10-90} : <ul style="list-style-type: none"> – Max. 800 ms at exhaust gas velocity 3 m/s – Max. 300 ms at exhaust gas velocity 12 m/s The maximum response time may increase depending on the mounting position and the geometry of the exhaust system.
Light-off time oxygen (O ₂)	Max. 33 s after dew point release at supply voltage 16 V ± 0,2 V
Exhaust gas velocity	Supply voltage 13.8 V to 32 V: 10 m/s to 140 m/s Supply voltage 10.7 V to < 13.8 V: 10 m/s to 60 m/s
NO ₂ correction factor (K _{NO2})	0.82 (set ex works)

Table 1: Measuring accuracy nitric oxide (NO)

Measurement	Measuring accuracy
0 ppm	± 5 ppm abs
10 ppm	± 7 ppm abs
100 ppm	± 7 ppm abs (± 7 % rel)
500 ppm	± 40 ppm abs (± 8 % rel)
1,500 ppm	± 150 ppm abs (± 10 % rel)
2,750 ppm	± 468 ppm abs (± 17 % rel)

Table 2: Measuring accuracy oxygen (O₂)

Measurement	Measuring accuracy	Gas composition
0 %	± 0.2 % abs	N ₂ with 1 % H ₂ O
5 %	± 0.25 % abs	5 % O ₂ in N ₂ ; 0 % H ₂ O
20.95 %	± 5 % rel	20.95 % O ₂ in N ₂ ; 0 % H ₂ O

4.1.6 Interfaces

CAN Bus Interface

- Classical Extended Frame Format (CAN 2.0B)
- Network protocol: SAE J1939
- Transmission rate: 250 kbit/s or 500 kbit/s (automatic detection)

4 Product Description

4.1.7 Overview Drawings

Dimensions

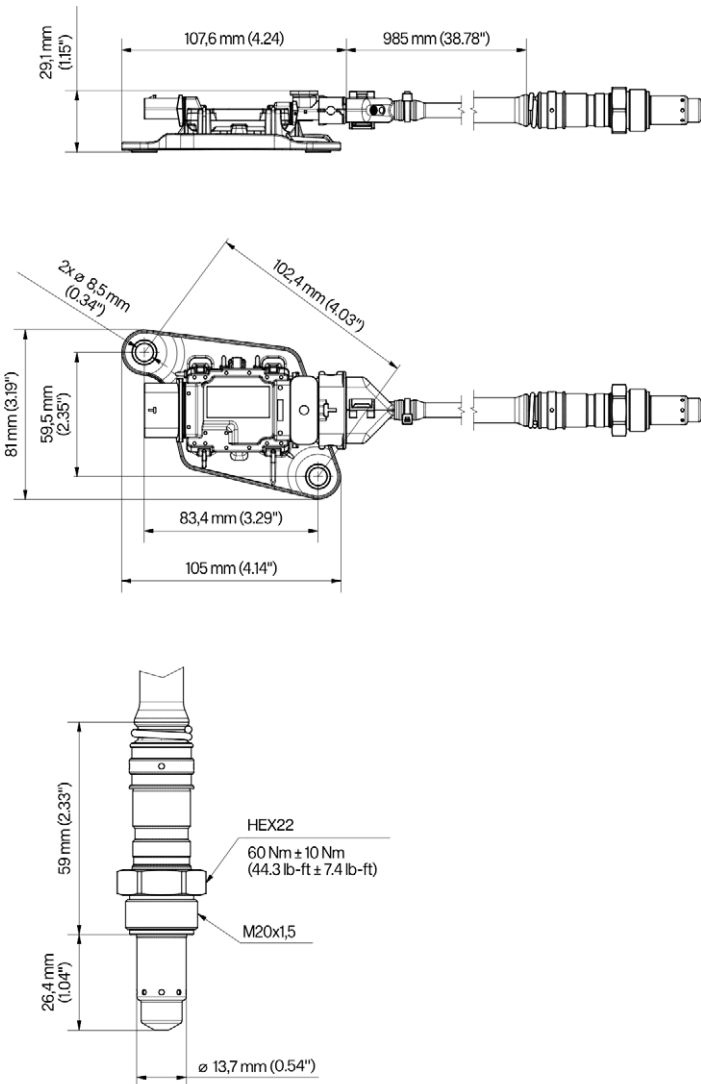

5.1 Output of Measured Values

The NO_x sensor only outputs valid measured values when the sensing element is at working temperature (see section *Heating Modes* on page 17). Via the CAN bus, the NO_x sensor indicates for each measured value whether the measured value is valid or invalid. Further information on the output of measured values via the CAN bus can be found in the CAN bus documentation of the NO_x sensor P/N 56.03.005, which is available on request from your MOTORTECH contact person (see *Customer Service Information* on page 27).

5.2 Heating Modes

The NO_x sensor operates in the following three heating modes:

- **Protective Heating**
As soon as the NO_x sensor is supplied with power, the NO_x sensor is operated with a low heating power to prevent the formation of condensation water in the sensing element. In this mode, the CAN interface of the NO_x sensor is already accessible, but the NO_x sensor does not yet output valid measured values.
- **Heat-up**
After the NO_x sensor has received the dew point release from the master control via the CAN bus, the NO_x sensor heats up the sensing element until its working temperature is reached. The evaluation unit of the NO_x sensor transmits the status of whether the sensing element is at working temperature as well as the heating status to the master control via a CAN message.
- **Measurement**
As soon as the sensing element is stably at working temperature, the NO_x sensor outputs valid measured values via the CAN bus after the respective light-off times have elapsed.

5.3 Readable Correction Factors

On request, the evaluation unit of the NO_x sensor provides the following correction factors in the CAN bus:

- O₂ pressure correction
- NO_x pressure correction
- NO₂ correction (K_{NO2})
- NH₃ correction (K_{NH3})
- NO_x new part deviation gain
- NO_x new part deviation offset

Further information on reading out the correction factors can be found in the CAN bus documentation of the NO_x sensor P/N 56.03.005, which is available on request from your MOTORTECH contact person (see *Customer Service Information* on page 27).

5.4 Automatic Bit Rate Detection in CAN Bus

The NO_x sensor can operate at bit rates of 250 kbit/s and 500 kbit/s. As soon as the NO_x sensor is supplied with voltage, it automatically adjusts itself to the bit rate in accordance with the messages received in the CAN bus. It is only after this automatic adjustment that the NO_x sensor sends CAN messages.

6 Installation Instructions



Replacement of NO_x sensor in EasyNO_x system

If you want to replace a NO_x sensor from MOTORTECH in the exhaust pipe, read the relevant sections in the EasyNO_x operating manual on replacing a NO_x sensor P/N 56.03.005.

6.1 Preparation

Make sure that your application meets the following requirements.

6.1.1 Mounting Position of Sensing Element

The NO_x sensor is only suited for measurement when mounted in an exhaust pipe.

The mounting position of the sensing element must be defined in such a way that no condensation water is able to collect in the protective tube of the sensing element.

A pipe connected to the exhaust system (e.g. for changing the gas mass flow or gas pressure) must not be located in the environment of the sensing element.

If the intake pipe is located near the sensing element, the distance between the sensing element and the intake pipe must be chosen in a way that condensed liquid droplets will not stream back to the sensing element due to gas pulsation.

In systems with urea injection, if the sensing element is to be mounted near the injection point, the sensing element should be mounted prior to the injection point, and it should be ensured that no urea flows back to the sensing element.

When mounting the sensing element after the catalytic converter, make sure that no material escapes from the catalytic converter.

The possible tilt angles of the sensing element depend on the course of the exhaust pipe. Mounting in a vertical exhaust pipe is not recommended by MOTORTECH.

Tilt angles horizontal exhaust pipe

Recommendation: 0°

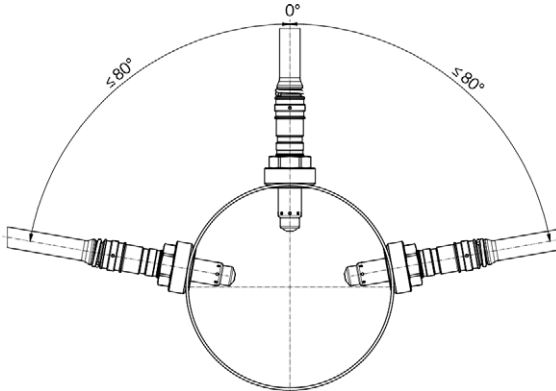

Recommendation: 0°

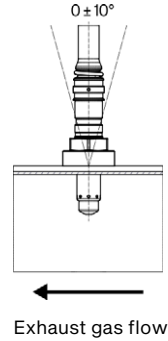

Tilt angles vertical exhaust pipe

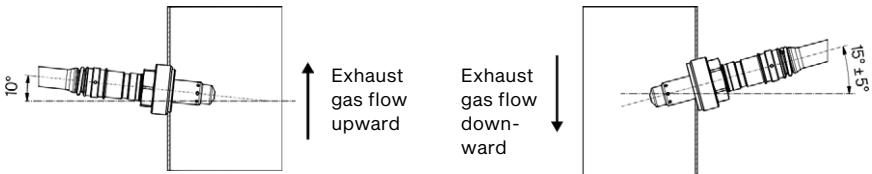

The sensing element heats up as soon as the NO_x sensor is powered. Therefore, the sensing element must be installed on the exhaust pipe at a suitable location at which people at the plant cannot be burned by it, or an appropriate protection must be installed around the sensing element that prevents contact with it. Also keep flammable or ignitable materials that could burst or burn away from the sensing element.

Furthermore, make sure that the sensing element of the NO_x sensor does not overheat at the mounting location. Avoid accumulated heat at the sensing element and ensure sufficient ventilation of the sensing element by ambient air. Also comply with the specified temperature limits (see section *Mechanical Data* on page 13).

6.1.2 Mounting Position of Evaluation Unit

To prevent the formation of discharge sparks or electric shock when touching the housing, the evaluation unit of the NO_x sensor must be mounted on a grounded metal mounting plate. The mounting position of the mounting plate should be free from vibrations.

6 Installation Instructions

6.1.3 Laying the Connection Cable

The connection cable between the sensing element and the evaluation unit cannot be detached.

To ensure proper functioning of the connection cable, the minimum bending radius of the connection cable of 20 mm (0.79") must be adhered to at the mounting position and the first bend of the connection cable must maintain a minimum distance of 30 mm (1.18") on each end.

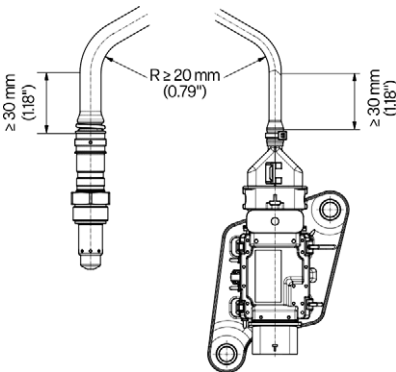

There must be no pull on the connection cable. Also, it must be possible to lay the connection cable in such a way that it is not affected by heat-conducting or heat-radiating components.

6.1.4 External Power Supply



Risk of injury!

The NO_x sensor is designed for operation in circuits with **protected extra-low voltage (PELV)**. The voltages in these circuits must not exceed 50 V AC or 75 V DC. To protect the circuit against overload and short circuits, the supply voltage cable must be secured with a suitable fuse (max. 10 A).

6.2 Unpacking

Before unpacking, observe the instructions in section *Proper Transport* on page 11.

To prevent condensation from forming in the sensing element of the NO_x sensor, you should avoid any temperature shocks when opening the packaging. Before opening, allow the shipping unit to adjust to the mounting temperature, and after having opened it, avoid temperature changes. The NO_x sensor must not be taken out of its packaging in polluted air and under bad weather conditions (e.g. oil, water, snow, dust, sand, smoke).

Do not remove the protective cap from the sensing element until you are instructed to do so within this installation instruction (see section *Mounting* on page 21).

6.3 Material Needed

For mounting the NO_x sensor, you need the following material:

- Suitable welding boss from MOTORTECH
- Locking screw for welding boss from MOTORTECH
- Suitable harness for connecting the NO_x sensor to the master control (optionally available from MOTORTECH)

If you have any questions about the needed material, contact your MOTORTECH contact person (see *Customer Service Information* on page 27).

6.4 Mounting



Risk of poisoning!

People at the plant can be poisoned by exhaust gases escaping from the exhaust pipe. To prevent this, the NO_x sensor must be mounted on the exhaust pipe in a gas-tight manner. Therefore, check the welding boss and the locking screw for visible damage before and during mounting.



Operational safety!

To safely mount the NO_x sensor, be sure to observe the following:

- To protect the NO_x sensor and yourself, wear ESD-compliant work gloves. To protect the NO_x sensor against electrostatic discharge, also comply with IEC 61340-5-1 and IEC TR 61340-5-2 in their respective valid versions.
- Under no circumstances touch the probe of the sensing element while mounting.

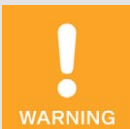

Operational safety!

The NO_x sensor must not be used any further under any circumstances if it is damaged or the sensing element of the NO_x sensor has been mechanically shocked (e.g. by dropping it on the floor or impacts on the sensing element). In these cases, contact MOTORTECH for sensor replacement (see *Customer Service Information* on page 27).

6 Installation Instructions



Operational safety!

Proper functioning of the NO_x sensor is only guaranteed if the sensing element does not overheat at the mounting location. Avoid accumulated heat at the sensing element and ensure sufficient ventilation of the sensing element by ambient air.



Operational safety!

Proper functioning of the NO_x sensor is only guaranteed under the following conditions:

- The sensing element may be dismantled and mounted a maximum of five times, provided that its thread is re-greased with one of the recommended greases in the recommended amount, as specified in the installation instruction, before the sensing element is remounted.
- The electrical connection to the NO_x sensor's evaluation unit may be disconnected and reestablished a maximum of 5 times.

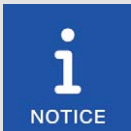

Replacement of NO_x sensor in EasyNO_x system

If you want to replace a NO_x sensor from MOTORTECH in the exhaust pipe, read the relevant sections in the EasyNO_x operating manual on replacing a NO_x sensor P/N 56.03.005.

Before mounting, it is essential to observe the instructions in the section *Preparation* on page 18.

Make sure that the engine is switched off when mounting. Also make sure that the exhaust pipe has cooled down sufficiently and that there are no exhaust gases in the exhaust pipe.

The sensing element of the NO_x sensor is screwed into the exhaust pipe via a suitable welding boss made of stainless steel (material number 1.4301) from MOTORTECH. For welding in the welding boss, the locking screw of the welding boss can be used as welding aid.

Proceed as follows:

1. First mount the evaluation unit of the NO_x sensor with two suitable screws onto a grounded mounting plate at the mounting position specified by you. The diameter of the mounting holes is 8.4 mm (0.33").

- Then, at the selected mounting position in the exhaust pipe, drill a hole with a diameter of 27 mm ± 1 mm (1.07" ± 0.04") into the exhaust pipe for the sensing element.

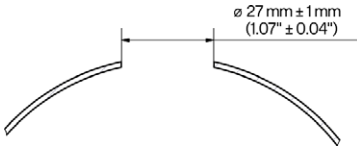

- Screw the locking screw into the welding boss and weld the stainless steel welding boss (material number 1.4301) into this hole with a suitable welding filler.



- Remove the protective cap from the probe of the sensing element. Do not pull on the connection cable, but hold the sensing element only by its metal body.
- When mounting the sensing element for the first time, check that its thread is sufficiently greased. When remounting the sensing element (maximum 5 mounting cycles), its thread must be re-greased. If necessary, re-grease only the thread of the sensing element evenly with about 100 mg of high-temperature grease. MOTORTECH recommends the following greases: Molub-Alloy Paste MF and Optimol Paste MF from Castrol® and Never Seez Regular Grade from Bostik®. Also make sure that no dirt, dust, or grease gets deposited in or on the probe while mounting.
- Insert the sensing element into the welding boss and screw the sensing element into the welding boss via its hexagon nut by hand first. The outgoing wires must not twist in the process. Therefore counter the sensing element with your hand.
- Then tighten the sensing element over its hexagon nut using a calibrated torque tool with a torque of 60 Nm ± 10 Nm (44.3 lb-ft ± 7.4 lb-ft).

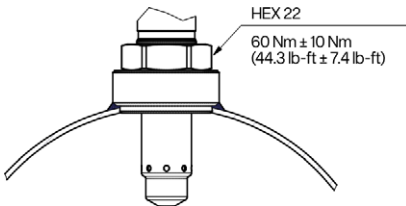

- Then lay the connection cable between the sensing element and the evaluation unit. When doing so, comply with the specifications in the section *Laying the Connection Cable* on page 20.

- ▶ The NO_x sensor is mounted.

6 Installation Instructions

6.5 Wiring

Only wire the NO_x sensor to the master control and to the power supply in disconnected state.

For connecting the NO_x sensor to the master control and to the power supply and for selecting the CAN identifier of the NO_x sensor (see *Setting CAN Identifier* on page 24), suitable harnesses are available from MOTORTECH.

If you want to apply your own solution, use a suitable mating plug to the five-pole connector of the NO_x sensor's evaluation unit (see *Electrical Data* on page 14) and make sure that your wiring complies with the following specifications:

Pin evaluation unit	Assignment	Cable type	Cross section	Wire length
1	L +	Unshielded	≥ 1 mm ²	< 15 m (49')
2	L –			
3	CAN Lo	Shielded CAN cable	0.2 mm ²	250 m (820')
4	CAN Hi			
5	CAN identifier of NO _x sensor	Shielded	0.2 mm ²	< 30 m (98')
		Unshielded		< 3 m (9')

When making the plug connection, make sure that the five-pole connector of the NO_x sensor's evaluation unit is dry and that there are no particles or deposited grease in the connector. In addition, do not apply any lubricants to make the plug connection. The harness and cables should be routed in such a way that there is no pull on them or the evaluation unit. If you use cable fasteners, they should not exert any force on the harness or cables.

The NO_x sensor has a pulsed current consumption. MOTORTECH therefore recommends that you route the supply voltage cable and the ground cable in parallel and without branches to other devices.

6.6 Setting CAN Identifier

Three CAN identifiers are predefined in the NO_x sensor so that a maximum of three of these sensors can be operated together in one CAN bus. The CAN identifier is selected externally via pin 5 of the NO_x sensor's connector.

- 0x18F00E51 = Parameter group number 61454, source address 81:
Pin 5 is connected to ground.
- 0x18F00F52 = Parameter group number 61455, source address 82:
Pin 5 is open.
- 0x18F0E964 = Parameter group number 61673, source address 100:
Pin 5 is connected to plus.

Additionally, take note that the NO_x sensor detects the bit rate in the CAN bus automatically and only sends CAN messages when it has adjusted itself to the bit rate in the CAN bus (see section *Automatic Bit Rate Detection in CAN Bus* on page 17).

6.7 Setting up Master Control

Before you can perform measurements with the NO_x sensor, the master control must be configured in certain cases.

If you use a master control from MOTORTECH that is designed for use with the NO_x sensor (e.g. EasyNO_x), please refer to the operating manual of the master control for more information.

If you use some other master control, it must usually be adapted for communication with the NO_x sensor via the CAN bus. Further information on this can be found in the CAN bus documentation of the NO_x sensor P/N 56.03.005, which is available on request from your MOTORTECH contact person (see *Customer Service Information* on page 27). Likewise, in certain cases, the measured values sent by the NO_x sensor must also be subjected to corrective calculations in the master control.

6.8 Dismounting



Operational safety!

To safely dismount the NO_x sensor, be sure to observe the following:

- To protect the NO_x sensor and yourself, wear ESD-compliant work gloves. To protect the NO_x sensor against electrostatic discharge, also comply with IEC 61340-5-1 and IEC TR 61340-5-2 in their respective valid versions.
- Under no circumstances touch the probe of the sensing element while dismounting.
- The NO_x sensor must not be live during dismounting and must have cooled down for at least 15 minutes after the voltage has been switched off. Otherwise, touching the sensing element may cause burns, the sensing element may burn, and serious damage to the connected equipment due to sparking or a short circuit may occur.



Operational safety!

The NO_x sensor must not be used any further under any circumstances if it is damaged or the sensing element of the NO_x sensor has been mechanically shocked (e.g. by dropping it on the floor or impacts on the sensing element). In these cases, contact MOTORTECH for sensor replacement (see *Customer Service Information* on page 27).

6 Installation Instructions



Operational safety!

Proper functioning of the NO_x sensor is only guaranteed under the following conditions:

- The sensing element may be dismantled and mounted a maximum of five times, provided that its thread is re-greased with one of the recommended greases in the recommended amount as specified in the installation instruction before the sensing element is remounted (see section *Mounting* on page 21).
- The electrical connection to the NO_x sensor's evaluation unit may be disconnected and reestablished a maximum of 5 times.

Make sure that the engine is switched off while dismantling. Also make sure that the exhaust pipe has cooled down sufficiently and that there are no exhaust gases in the exhaust pipe.

To dismantle the NO_x sensor, proceed as follows:

1. Make sure that the NO_x sensor is not live. Then disconnect the mating plug of the MOTORTECH harness or your wiring from the connector of the evaluation unit.
2. Make sure that the sensing element has not been live for at least 15 minutes. Then unscrew the sensing element from the welding boss using a flare nut wrench 22 mm (0.87") with a spared corner wave profile. The outgoing wires must not twist in the process. Therefore counter the sensing element with your hand. Do not use a hammer or a flat spanner to loosen the sensing element.
3. Dismount the evaluation unit from the mounting plate.
 - ▶ The NO_x sensor has been dismantled.

If you do not screw a suitable sensing element into the welding boss after having removed the NO_x sensor, you may only restart the engine after having sealed the opening in the exhaust pipe gas-tight. For this purpose, use the locking screw of the welding boss. Grease the locking screw sufficiently with high temperature grease before inserting it into the welding boss. If you want to insert a NO_x sensor P/N 56.03.005 into the welding boss at a later time, use one of the following MOTORTECH-recommended greases: Molub-Alloy Paste MF or Optimol Paste MF from Castrol® or Never Seez Regular Grade from Bostik®. Screw down the locking screw into the welding boss with a torque of 25 Nm (18.5 lb-ft).

7.1 Error Detection

The evaluation unit of the NO_x sensor detects electrical faults (short-circuits and open wires) in the lines between the sensing element and the evaluation unit and signals these to the master control via the CAN bus. If an electrical fault has been detected, the NO_x sensor operates in diagnostic mode and remains in this mode even after elimination of the electrical fault, until the dew point release is set or reset, or the NO_x sensor is reset by an intermediate disconnection from the power supply.

Further information on errors reported via the CAN bus can be found in the CAN bus documentation of the NO_x sensor P/N 56.03.005, which is available on request from your MOTORTECH contact person (see *Customer Service Information* on page 27).

7.2 Self-Diagnosis

The NO_x sensor has a self-diagnosis function that can be triggered by the master control via a CAN message. Further information on the self-diagnosis can be found in the CAN bus documentation of the NO_x sensor P/N 56.03.005, which is available on request from your MOTORTECH contact person (see *Customer Service Information* on page 27).

7.3 Customer Service Information

You can reach us during our business hours by:

Phone: +49 5141 93 99 0
Email: service@motortech.de (technical support)
sales@motortech.de (all other matters)

7.4 Returning Equipment for Repair/Inspection

To return the device for repair and inspection, first consult your MOTORTECH contact person (see *Customer Service Information* on page 27). From him you will receive all the information you need to process your order quickly and smoothly. For return shipment, also observe the instructions in the section *Instructions for Packaging the Equipment* on page 27.

7.5 Instructions for Packaging the Equipment

For return shipment, equipment should be packaged as follows:

- Use silicone-free packaging material that does not damage the equipment surfaces.
- Pack the NO_x sensor in such a way so that it is adequately protected against mechanical shocks.
- Wrap the equipment with sturdy materials and stabilize it inside the packaging.
- Use sturdy adhesive film to seal the packaging.

8 Maintenance

8.1 Cleaning the NO_x Sensor

The NO_x sensor must not be cleaned with mechanical means or cleaning agents, as this may destroy the sensor or mechanically damage the labels. The NO_x sensor including its electrical connection must not come into contact with liquids.

If necessary, clean the NO_x sensor with a soft, dry cloth. If you clean the NO_x sensor when it is not mounted, make sure that the probe remains free of dirt.

8.2 Spare Parts and Accessories

For spare parts and accessories, please refer to our current Product Guide, which is available for you to download on the internet at www.motortech.de.



MOTORTECH GmbH
Hunaeusstrasse 5
29227 Celle
Germany

☎ +49 5141 93 99 0
✉ sales@motortech.de
🌐 www.motortech.de

MOTORTECH Americas, LLC
1400 Dealers Avenue, Suite A
New Orleans, LA 70123
USA

☎ +1 504 355 4212
✉ info@motortechamericas.com
🌐 www.motortechamericas.com

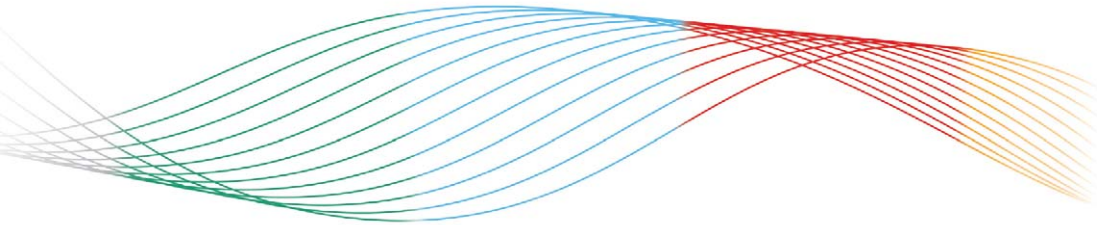

GAS ENGINE TECHNOLOGY

