

VariFuel2/2+ – Air/Gas Mixer

Assembly Instructions



P/N 01.50.001-EN | Rev. 01/2022

Original assembly instructions

© Copyright 2022 MOTORTECH GmbH. All rights reserved.

MOTORTECH products and the MOTORTECH logo are registered and/or common law trademarks of the MOTORTECH GmbH. All further trademarks and logos displayed or used in this publication are the property of the respective entitled person and are used for reference purposes only.

Information contained in this publication may be changed without prior notice.

Table of Contents



1 General Information	5
1.1 What Is the Purpose of these Assembly Instructions?	5
1.2 Who Are these Assembly Instructions Targeted to?	5
1.3 What Symbols Are Used in the Assembly Instructions?	5
1.4 Which Abbreviations/Acronyms Are Used in the Assembly Instructions?	6
2 Safety Instructions	7
2.1 General Safety Instructions	7
2.2 Electrostatic Discharge Hazards	8
2.3 Special Safety Instructions for the Device	8
2.4 Proper Transport	10
2.5 Proper Storage	10
2.6 Proper Disposal	10
3 Intended Use	11
3.1 Functional Description	11
3.2 Applications	13
4 Product Description	15
4.1 Technical Data	15
4.1.1 Certifications	15
4.1.2 Mechanical Data	16
4.1.3 Warning Notices on the Device	17
4.1.4 Product Identification – Labeling on the Device	18
4.1.5 Overview Drawings	19
4.1.6 Connector Stepper Motor / Encoder	26
4.1.7 Digression: Direct Control of Stepper Motor	27
5 Installation Instructions	28
5.1 Unpacking	28
5.2 Assembly	29
5.2.1 Install Flow Body	31
5.2.2 Install VariFuelz/2+ into Intake Section	33
5.2.3 Connect Stepper Motor Driver	35
6 Operation	36
6.1 Start-up	36
7 Errors	38
7.1 Special Tools for Troubleshooting	38
7.2 Possible Faults	38

■ Table of Contents

7.3 Fix Shaft	41
7.4 Adjust Fuel Ring.....	44
7.5 Customer Service Information	46
7.6 Returning Equipment for Repair / Inspection	46
7.7 Instructions for Packaging the Equipment	46
8 Maintenance	47
8.1 Maintenance Instructions.....	47
8.2 Spare Parts and Accessories	47
9 Index	48

Prior to use, read these assembly instructions carefully and familiarize yourself with the product. Installation and start-up should not be carried out before reading and understanding this document. Keep these assembly instructions readily available so that you can reference them as needed.

1.1 What Is the Purpose of these Assembly Instructions?

These assembly instructions serve as an aid for the installation and operation of the product and support the technical staff with all operating and maintenance tasks to be performed. Furthermore, these instructions are aimed at preventing dangers to life and health of the user and third parties.

1.2 Who Are these Assembly Instructions Targeted to?

These assembly instructions provide a code of conduct for personnel tasked with the setup, operation, maintenance, and repair of gas engines. A certain level of technical knowledge with respect to the operation of gas engines and basic knowledge of the electronic components used are necessary. Persons who are only authorized to operate the gas engine shall be trained by the operating company and shall be expressly instructed concerning potential hazards.

1.3 What Symbols Are Used in the Assembly Instructions?

The following symbols are used in these instructions and must be observed:



Example

This symbol indicates examples, which point out necessary handling steps and techniques. In addition, you receive additional information from the examples, which will increase your knowledge.



Notice

This symbol indicates important notices for the user. Follow these. In addition, this symbol is used for overviews that give you a summary of the necessary work steps.



Warning

This symbol indicates warnings for possible risks of property damage or risks to health. Read these warning notices carefully and take the mentioned precautionary measures.

1 General Information



Danger

This symbol indicates warnings for danger to life, especially due to high voltage. Read these warning notices carefully and take the mentioned precautionary measures.

1.4 Which Abbreviations/Acronyms Are Used in the Assembly Instructions?

The following abbreviations/acronyms are used in the assembly instructions:

Abb.	Term	Description	Explanation
CE	Conformité Européenne	Conformity with EU directives	Mark based on EU legislation for certain products in conjunction with product safety
CPR	Counts Per Revolution		Unit for the resolution of encoders
EMC	Electromagnetic Compatibility		Compatibility of electrical or electronic equipment items with their surroundings
ESD	Electrostatic Discharge		
LNG	Liquefied Natural Gas		Natural gas liquefied by cooling
LPG	Liquefied Petroleum Gas		Petroleum gas liquefied by cooling and compressing
TTL	Transistor–Transistor Logic		Circuit technology for logic circuits

2.1 General Safety Instructions

MOTORTECH equipment is manufactured as state of the art and therefore safe and reliable to operate. Nevertheless the equipment can cause risks or damage can occur, if the following instructions are not complied with:

- The gas engine must only be operated by trained and authorized personnel.
- Observe all safety instructions of the system and all safety instructions of the system operator.
- Operate the equipment only within the parameters specified in the technical data.
- Use the equipment correctly and for its intended use only.
- Never apply force.
- For all work such as installation, conversion, adaptation, maintenance, and repair, all equipment must be disconnected from the mains and secured against unintentional reactivation.
- Perform only such maintenance and repair work as is described in these assembly instructions, and follow the instructions given while working.
- Only use spare parts supplied by MOTORTECH for the maintenance of the device.
- Further work must only be performed by personnel authorized by MOTORTECH. Non-compliance with the instructions will void any warranties for the proper function of the equipment as well as the responsibility for the validity of the certifications.
- Safety devices must not be dismounted or disabled.
- Avoid all activities that can impair the function of the equipment.
- Operate the equipment only while it is in proper condition.
- Investigate all changes that occur during operation of the gas engine or electronic engine control.
- Ensure compliance with all laws, directives, and regulations applicable to the operation of your system, including such not expressly stated herein.
- If the system is not entirely tight and sealed, gas may escape and result in explosion hazard. The inhalation of gas can also lead to death or severe health damages. Therefore, upon completion of all assembly works, always check the system's tightness.
- Always ensure adequate ventilation of the engine compartment.
- Ensure a safe position at the gas engine.
- There is a risk of burning on hot surfaces. Allow the gas engine to cool down before starting any work.
- Personal protective equipment (PPE), e.g. safety shoes and gloves, must be worn during all work on the gas engine.
- Noise from the system can cause permanent or temporary damage to your hearing. Wear suitable hearing protection at the system.
- Your behavior can reduce possible residual risks to a minimum. Observe responsible handling of the gas engine and the gas-carrying system.

2 Safety Instructions

2.2 Electrostatic Discharge Hazards

Electronic equipment is sensitive to static electricity. To protect these components from damage caused by static electricity, special precautions must be taken to minimize or prevent electrostatic discharge.

Observe these safety precautions while you work with the equipment or in its vicinity.

- Before performing maintenance or repair work, ensure that the static electricity inherent to your body is discharged.
- Do not wear clothing made from synthetic materials to prevent static electricity from building up. Your clothing should therefore be made of cotton or cotton mix materials.
- Keep plastics such as vinyl and Styrofoam materials as far away from the equipment as possible.
- Do not remove the circuit boards from the housing of the device.

2.3 Special Safety Instructions for the Device



Gas! Danger to life!

Leaking gas may cause death or serious health damage if inhaled. Upon completion of all assembly works, always check the system's tightness. When operating a VariFuel gas mixer, make sure that the gauge port is closed.

All works involving gas-carrying parts must be executed by trained personnel only.



Explosion hazard!

If the system is not entirely tight and sealed, gas may escape and result in explosion hazard. Upon completion of all assembly works, always check the system's tightness.

All works involving gas-carrying parts must be executed by trained personnel only.



Explosion hazard!

Do not disconnect any connectors while the system is live. If the system is located in a hazardous area, there is a risk of explosion.

2 Safety Instructions



Operational safety!

All screws of the connectors must be adequately tightened.



Operational safety!

Contaminated gas can lead to blocking of the fuel ring and thus can cause the gas engine to stop. Examine the VariFuel2/2+ regularly for contamination as a part of the regular maintenance intervals customary for your system. Use clean gas preferably.



Risk of destruction due to electrostatic discharge!

The VariStep3 stepper motor driver may only be installed by specialized personnel who has been trained in handling ESD sensitive components and with due regard to relevant ESD standards. It must be installed into a control cabinet, and it must comply with the ESD standard IEC 61340-5-1:2016.

Damage caused by electrostatic discharge is not covered by warranty.



Risk of burning!

The surfaces of the system may heat up to high temperatures.



Risk of destruction!

The stepper motor of the VariFuel is not suitable for carrying or lifting a gas mixer. There is a danger that the stepper motor could break, and if the gas mixer were to fall, it could result in injury or property damage.

Always carry or lift the gas mixer by its exterior housing.



Danger of interference with radio reception!

The device is not intended for use in residential areas and cannot ensure adequate protection of radio reception in such environments.

■ 2 Safety Instructions

2.4 Proper Transport

Transport the VariFuel2/2+ to the installation site unopened in its original carton.

2.5 Proper Storage

Clean the VariFuel2/2+ gas mixer before storing. Store the VariFuel2/2+ gas mixer in a dry and clean place on even ground. For storage, place the VariFuel2/2+ upright on the flat support surface on the underside of the device.

2.6 Proper Disposal

After the expiration of its service life, MOTORTECH equipment can be disposed of with other commercial waste, or it may be returned to MOTORTECH. We will ensure its environmentally friendly disposal.

3.1 Functional Description

All graphics used in this section represent an example of a VariFuel2/2+ series 200-120.

Basic Design

The main task of the gas mixer is it to mix the fuel (gas) and the air so that an optimal combustion is ensured within the gas engine. Here, the decisive optimization parameters are a high degree of efficiency and low emissions that comply with relevant regulations.

In the VariFuel2/2+, gas and air are mixed based on the Venturi principle. Based on the suction pressure of the engine, the air is sucked in through the air inlet **a** into the Venturi nozzle. This creates an underpressure at the most narrow place, which causes the gas to be sucked in through the gas inlet **b**. In this way, both the gas and the air are mixed and released at the mixture outlet **c**. The volume flow and thus the air/gas mixture can be adapted to the respective engine by using different design sizes and different flow bodies in the Venturi nozzle.

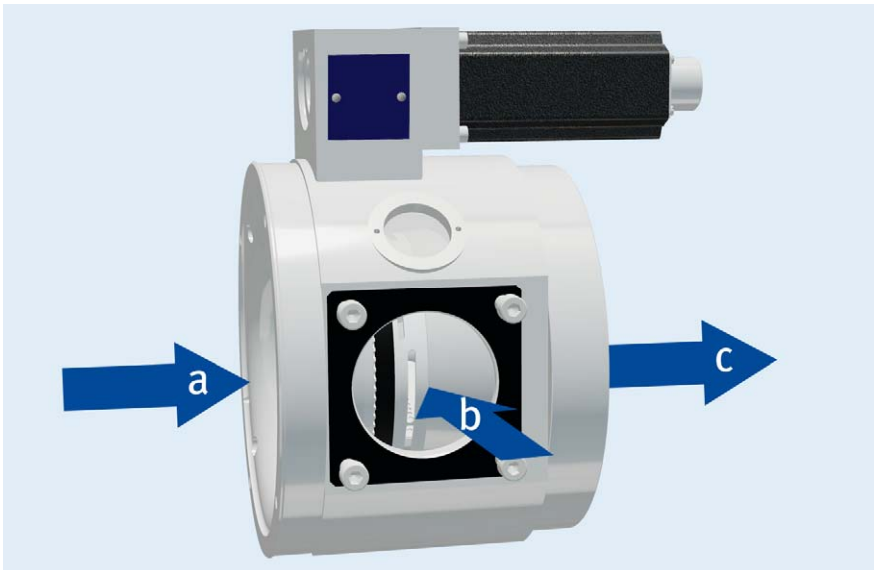

3 Intended Use

Mixture Control

The fuel (gas) is guided into the nozzle using the adjustable rectangular openings in a fuel ring **d**, which are wedge-shaped in the VariFuel2+. The openings of the fuel ring are adjusted by a stepper motor and a drive belt **e**. The stepper motor of the VariFuel2+/2+ is controlled by a stepper motor driver. This can process the signals of a master control.

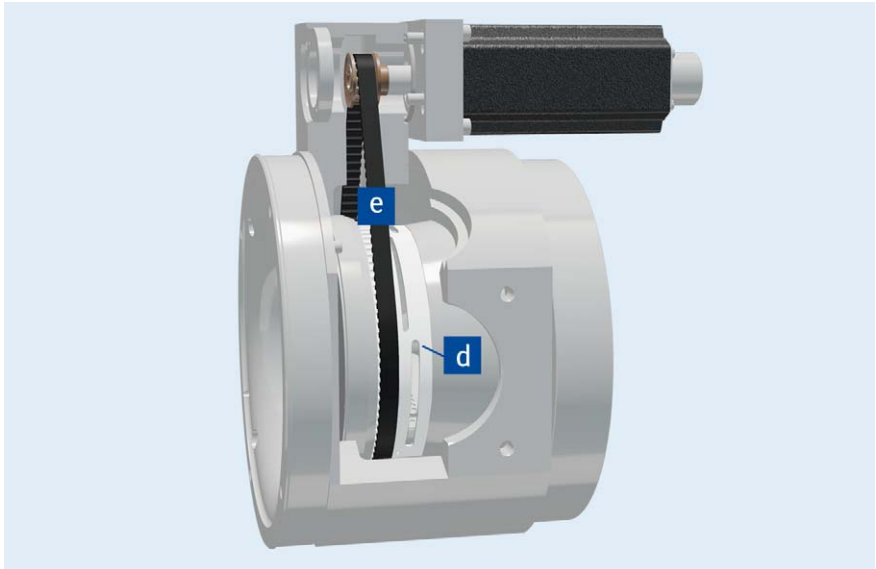

Connections

All VariFuel2/2+ gas mixers also have the following connections:

- An impulse line connection for connecting the air inlet to a balance or zero pressure regulator
- A gauge port for measuring the gas pressure at the gas inlet by a pressure gauge

3.2 Applications



Danger of interference with radio reception!

The device is not intended for use in residential areas and cannot ensure adequate protection of radio reception in such environments.

All VariFuel2/2+ air/gas mixers are designed for use with gas-powered Otto engines. The following substances are approved as fuels:

- Natural gas, biogas, landfill gas, sewage gas, wood gas, drilling-related gas, mine gas, liquefied natural gas (LNG), liquefied petroleum gas (LPG)
- Additional special gases may be used upon approval (there may be restrictions in the case of excessive moisture content or foreign materials in the gas such as tar)

Mixing the air and fuel with the VariFuel2/2+ must be done with the same pressure, therefore it is necessary to use a balance or a zero pressure regulator within the gas train.

The VariFuel2/2+ can mix up to two gases with air. For lean gas applications (such as wood or landfill gas) with a V-engine, it is possible to interconnect two VariFuel2/2+ to achieve the desired mixing ratio.

If two VariFuel2/2+ gas mixers are to be used, two VariStep3 stepper motor drivers are required. An additional splitter is not necessary.

Any use other than the one described in the assembly instructions shall be considered improper use and will result in the voiding of all warranties.

3 Intended Use

System Overview (Example)

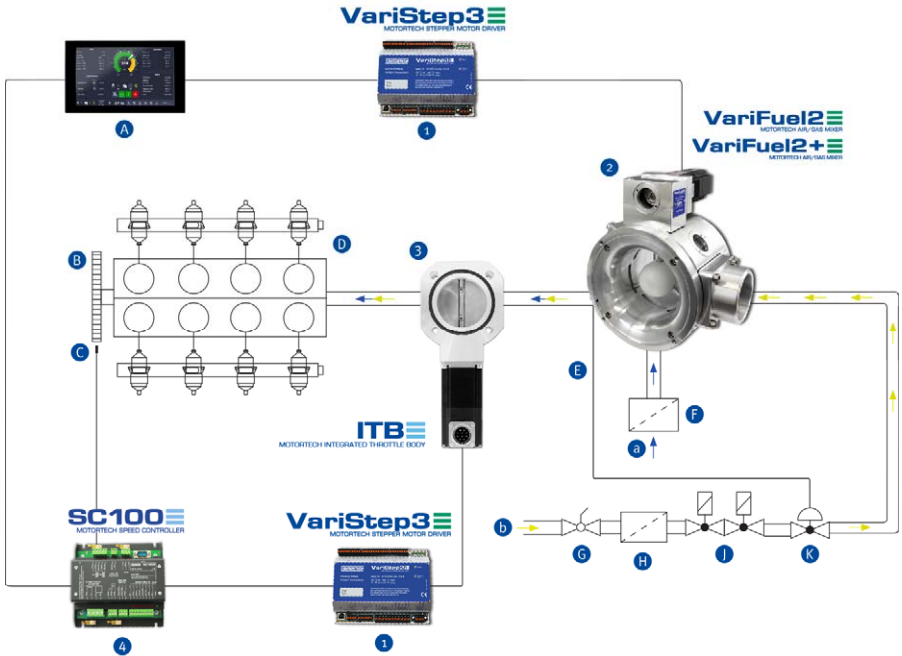

- 1 VariStep3 stepper motor driver
- 2 VariFuel2/2+ gas mixer
- 3 ITB throttle with integrated stepper motor
- 4 SC100 speed controller

- A Master control
- B Flywheel
- C Magnetic pickup
- D Engine
- E Impulse line
- F Air filter
- G Ball valve
- H Gas filter
- J Double safety valve
- K Balance/Zero pressure regulator

- a Air
- b Gas

4 Product Description



4.1 Technical Data

4.1.1 Certifications

The VariFuel2/2+ air/gas mixers are certified as follows:

CE

Machinery Directive

- The VariFuel2/2+ air/gas mixers are partly completed machinery according to article 2g of the EC Machinery Directive.
- The partly completed machine may only be commissioned once it has been established that the machine into which the product mentioned above should be incorporated complies with the provisions of the EC Machinery Directive.
- The following standards were considered:
 - EN ISO 12100 – Safety of machinery - General principles for design - Risk assessment and risk reduction
 - EN 60204-1 – Safety of machinery - Electrical equipment of machines - Part 1: General requirements

EMC Directive

- EN 55011 – Industrial, scientific and medical equipment - Radio-frequency disturbance characteristics - Limits and methods of measurement
 - Group 1, Class A
- EN 60034-1 – Rotating electrical machines - Part 1: Rating and performance
- EN 61000-6-2 – Electromagnetic compatibility (EMC) - Part 6-2: Generic standards - Immunity for industrial environments

The Declaration of Incorporation and the EU Declaration of Conformity of your VariFuel2/2+ are enclosed with your product.

4 Product Description

4.1.2 Mechanical Data

The devices of VariFuel2/2+ series have the following mechanical characteristics:

Feature	Value
Dimensions	See chapter <i>Overview Drawings</i> on page 19
Weight	<p>Series 100-60: 4.7 kg (10.4 lbs)</p> <p>Series 140-80: 7.4 kg (16.3 lbs)</p> <p>Series 200-120: 9.4 kg (20.8 lbs)</p> <p>Series 250-150: 22.8 kg (50.3 lbs)</p> <p>Series 300-190: 29.5 kg (65 lbs)</p> <p>Series 350-225: 36.2 kg (79.8 lbs)</p>
Shape of device	See chapter <i>Overview Drawings</i> on page 19
Climatic environmental conditions	<p>VariFuel2: -10 °C to $+80\text{ °C}$ ($+14\text{ °F}$ to $+176\text{ °F}$)</p> <p>VariFuel2+: -20 °C to $+80\text{ °C}$ (-4 °F to $+176\text{ °F}$)</p> <p>Max. humidity without condensation up to 2,000 m (6,561') above sea level:</p> <ul style="list-style-type: none"> - 85 % at $+80\text{ °C}$ ($+176\text{ °F}$) - 60 % at -20 °C (-4 °F)
Air consumption min./max.	<p>Series 100-60: 100 m³/h to 650 m³/h</p> <p>Series 140-80: 200 m³/h to 1,300 m³/h</p> <p>Series 200-120: 500 m³/h to 3,200 m³/h</p> <p>Series 250-150: 1,800 m³/h to 5,200 m³/h</p> <p>Series 300-190: 3,400 m³/h to 8,500 m³/h</p> <p>Series 350-225: 6,000 m³/h to 12,000 m³/h</p>
Suitable for flow bodies with min./max. diameter	<p>Series 100-60: 23 mm to 45 mm</p> <p>Series 140-80: 23 mm to 72.5 mm</p> <p>Series 200-120: 23 mm to 105 mm</p> <p>Series 250-150: 23 mm to 110 mm</p> <p>Series 300-190: 35 mm to 140 mm</p> <p>Series 350-225: 35 mm to 150 mm</p>

4 Product Description

4.1.3 Warning Notices on the Device

Warning on Removable Gas Inlet Cover



Don't touch inside

Warning Symbol on Stepper Motor



Warning of hot surface

Warning Notice on Stepper Motor

CAUTION! Stepper motor rev. B only for use with VariStep stepper motor card.
Do not use stepper motor to lift or carry the device.

4 Product Description

4.1.4 Product Identification – Labeling on the Device

The necessary numbers for unique product identification are on the device:

Nameplate Air/Gas Mixer on Upper Part of Housing



Abb.	Meaning
P/N	Part number of the air/gas mixer
S/N	Serial number of the air/gas mixer

The field *Label Flow Body Size* is reserved for the label that comes with the flow body. For further information, refer to the section *Install Flow Body* on page 31.

Nameplate Stepper Motor



Abb.	Meaning
P/N	Part number of the stepper motor
PC	Production code
REV.	Revision of the stepper motor

4 Product Description

4.1.5 Overview Drawings

Components

The following drawing shows an example of a VariFuel2 series 200-120. The exact position of the individual parts varies slightly with other series. A detailed layout can be found in the subsequent section *Dimensions*.

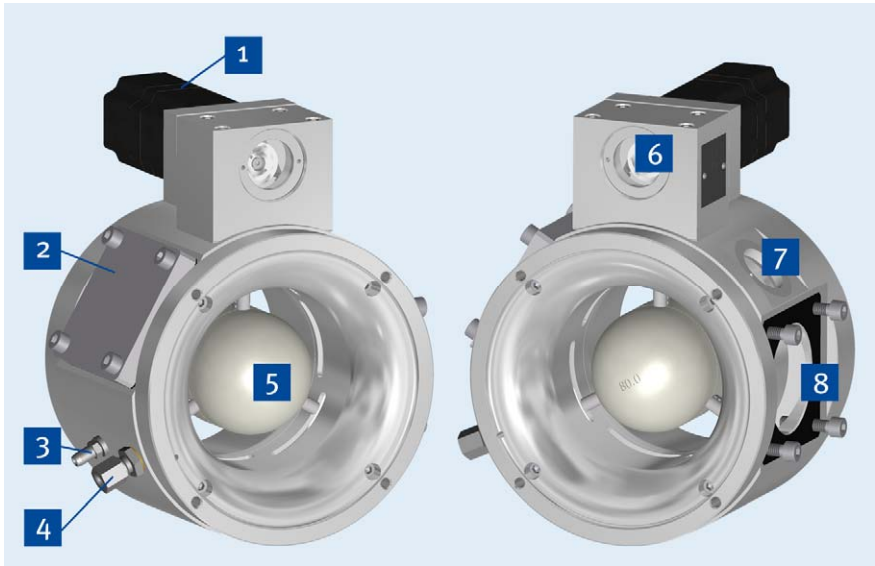

Pos.	Description
1	Stepper motor
2	Gas connection (here closed with a cover)
3	Gauge port G1/8 for gas pressure measurement at the gas inlet by a pressure gauge
4	Impulse line connection (cutting-ring connection) G1/4 for connecting the air inlet to a balance or zero pressure regulator
5	Flow body
6	Inspection window on the drive belt
7	Inspection window on the fuel ring
8	Gas connection

4 Product Description

Dimensions

Series 100-60

VariFuel2, VariFuel2+

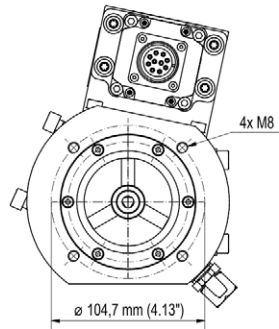
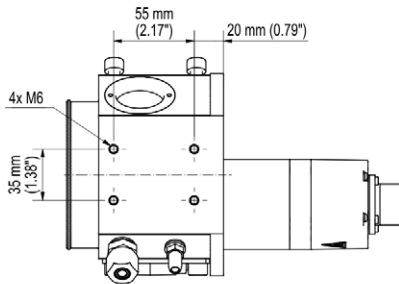
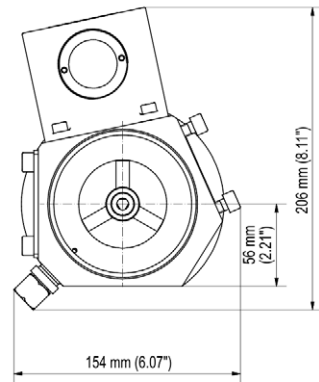
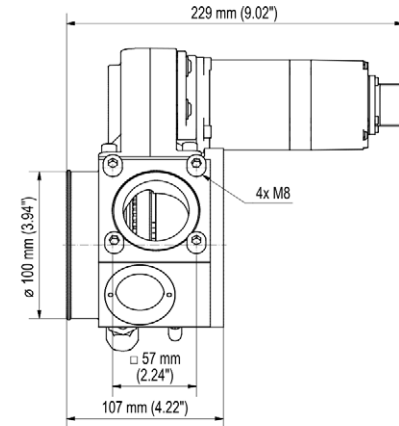

4 Product Description



Series 140-80 VariFuel2, VariFuel2+

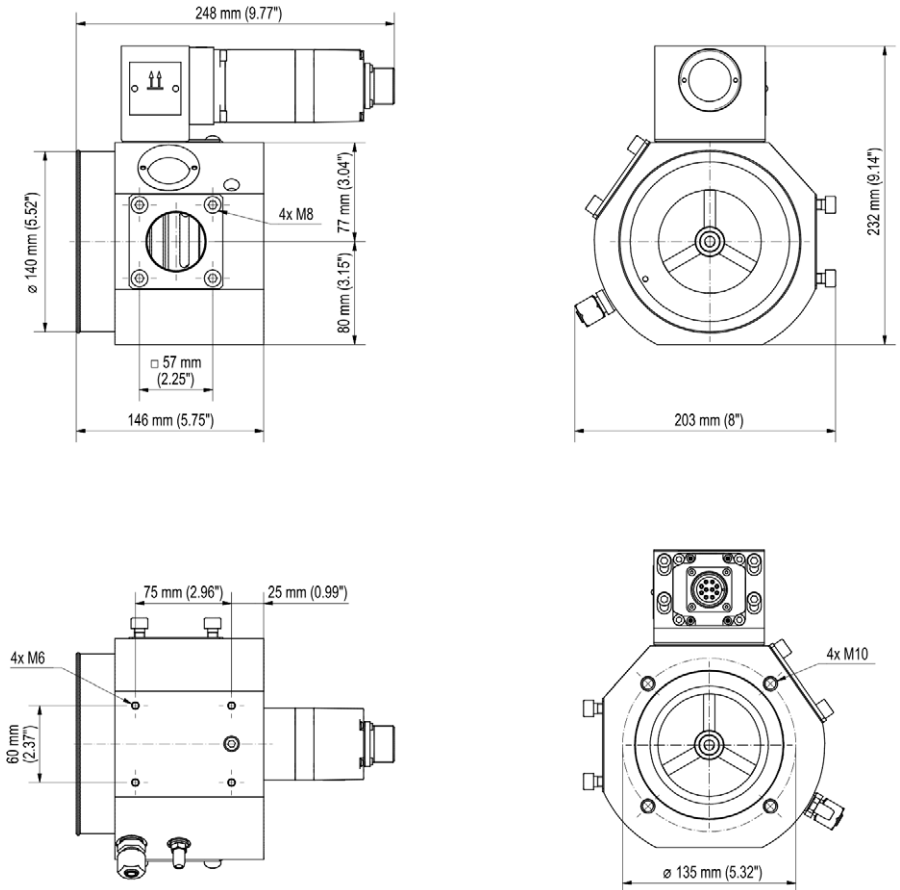

4 Product Description

Series 200-120
VariFuel2, VariFuel2+

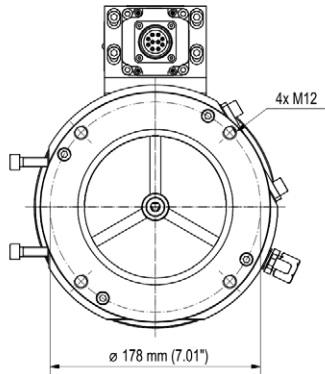
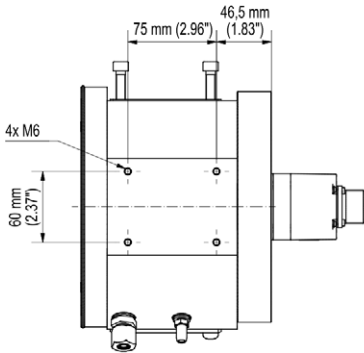
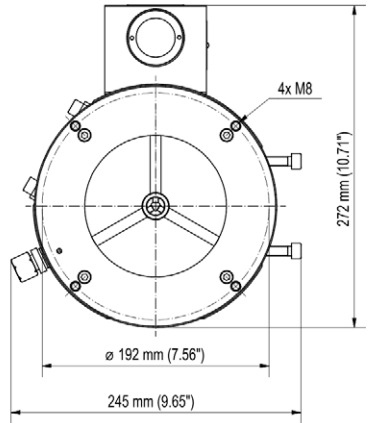
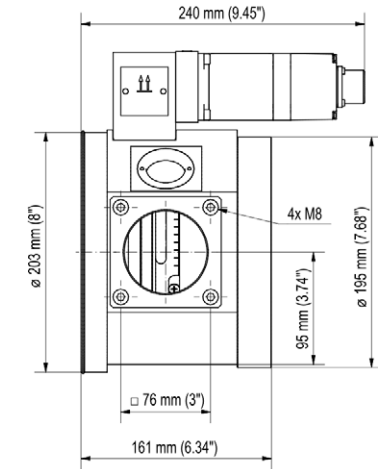

4 Product Description



Series 250-150 VariFuel2, VariFuel2+

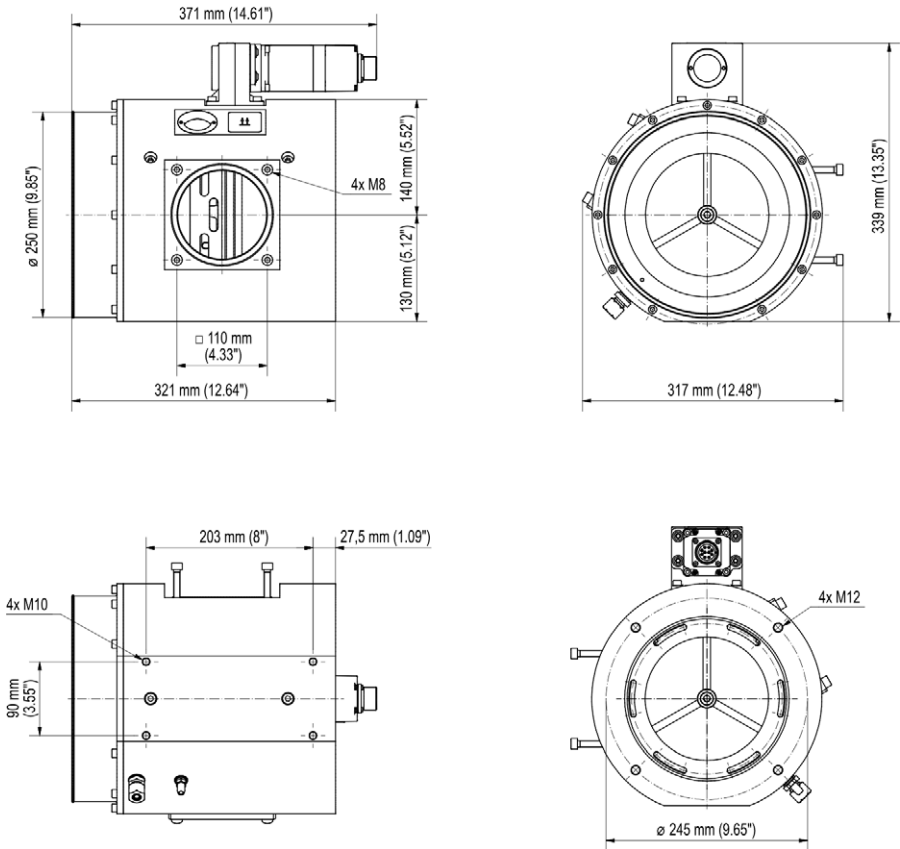

4 Product Description

Series 300-190
VariFuel2, VariFuel2+

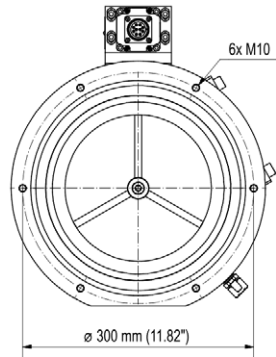
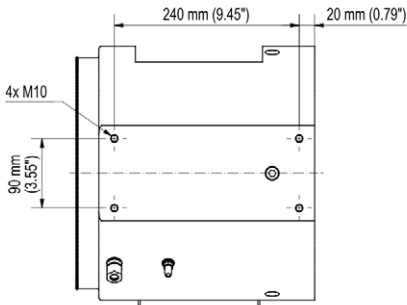
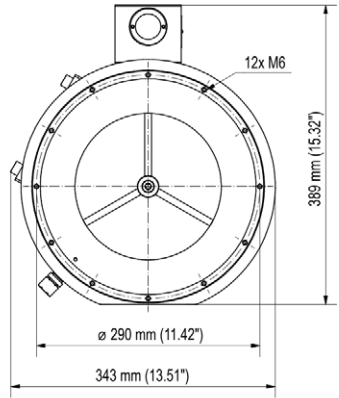
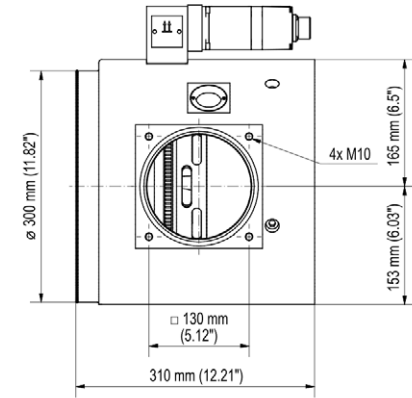

4 Product Description



Series 350-225 VariFuel2, VariFuel2+

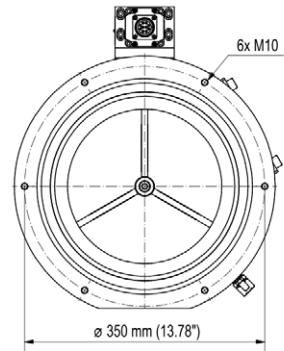
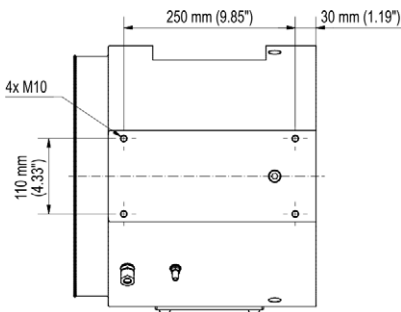
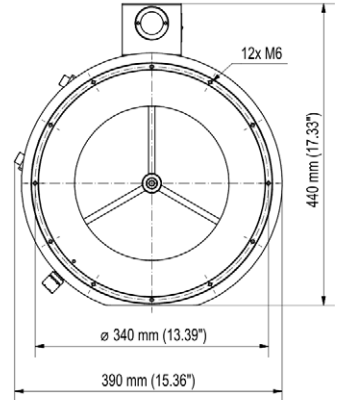
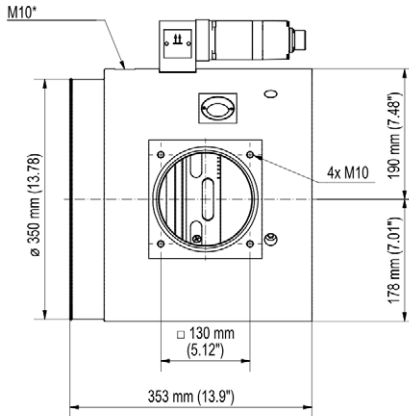

*for eye bolt DIN 580

4 Product Description

4.1.6 Connector Stepper Motor / Encoder

The connector on the stepper motor of the VariFuel2/2+ gas mixer is assigned as follows:

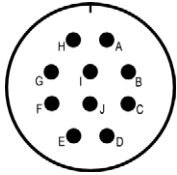

Pin	Description	Pin	Description
A	Stepper motor phase A1	F	Encoder B
B	Stepper motor phase A2	G	Encoder I (index)
C	Stepper motor phase B1	H	Encoder shield
D	Stepper motor phase B2	I	Encoder 5 V supply voltage
E	Encoder A	J	Encoder GND (ground)

4 Product Description



4.1.7 Digression: Direct Control of Stepper Motor

In the standard application, the stepper motor of the VariFuel2/2+ gas mixer is driven by the VariStep3 stepper motor driver. For example, if you want to implement a direct activation from a master control, you receive the technical details for activation of the stepper motor in the following section.

Technical Data of the Stepper Motor

Feature	Value
Design	2-phase, bipolar
Maximum phase current	2.8 A
Recommended current	1.4 A (full step operation mode) 2 A (microstep operation mode)
Step width	0.9°
Recommended control	1/16 microstep operation mode
Holding torque at maximum phase current	1.75 Nm (15.5 lb-in)
Rotation angle	Series 100-60: 192° Series 140-80: 250° Series 200-120: 330° Series 250-150: 230° Series 300-190: 278° Series 350-225: 306°

Technical Data of the Encoder

Feature	Value
Measuring method	Magnetic
Operating voltage	5 V
Type	Incremental, quadrature signal
Signal form	A, B, index; TTL-compatible
Resolution	4,096 CPR
Index position	Open position

You can find the assignment of the connectors on the stepper motor and encoder in the section *Connector Stepper Motor / Encoder* on page 26.

5 Installation Instructions

5.1 Unpacking

Unpack the device, taking care not to damage it, and ensure that the assembly instructions are always stored with the device and are easily accessible. Check the contents for completeness and verify that the device type meets your application requirements.



Risk of destruction due to electrostatic discharge!

The VariStep3 stepper motor driver may only be installed by specialized personnel who has been trained in handling ESD sensitive components and with due regard to relevant ESD standards. It must be installed into a control cabinet, and it must comply with the ESD standard IEC 61340-5-1:2016.

Damage caused by electrostatic discharge is not covered by warranty.

Scope of Supply

The scope of supply of the VariFuelz/2+ air/gas mixer consists of the following components:

- VariFuelz/2+ air/gas mixer
- Gasket for mixture outlet flange
- Assembly instructions
- Declaration of Incorporation
- EU Declaration of Conformity

Accessories

- Flow body
- Optional: Mounting flanges for gas inlet and mixture outlet
- Connection cable for connection between VariFuelz/2+ and VariStep3 stepper motor driver
- VariStep3 stepper motor driver incl. configuration software and USB interface cable

5.2 Assembly



Risk of destruction!

The stepper motor of the VariFuel is not suitable for carrying or lifting a gas mixer. There is a danger that the stepper motor could break, and if the gas mixer were to fall, it could result in injury or property damage.

Always carry or lift the gas mixer by its exterior housing.

The following steps must always be carried out and are specified in more detail in the following:

- Install flow body
- Install VariFuel2/2+ into intake section (air and gas inlet plus mixture outlet)
- Connect stepper motor driver

5 Installation Instructions

For optimum performance according to its design, it is important that air and fuel are mixed in the VariFuel2/2+ at the same pressure. Therefore, only operate the VariFuel2/2+ gas mixer with a balance or zero pressure regulator. The balance or zero pressure regulator must be connected to the impulse line connection of the VariFuel2/2+ and it must be installed in the gas train at a suitable position before the gas inlet of the VariFuel2/2+.

Connection Example

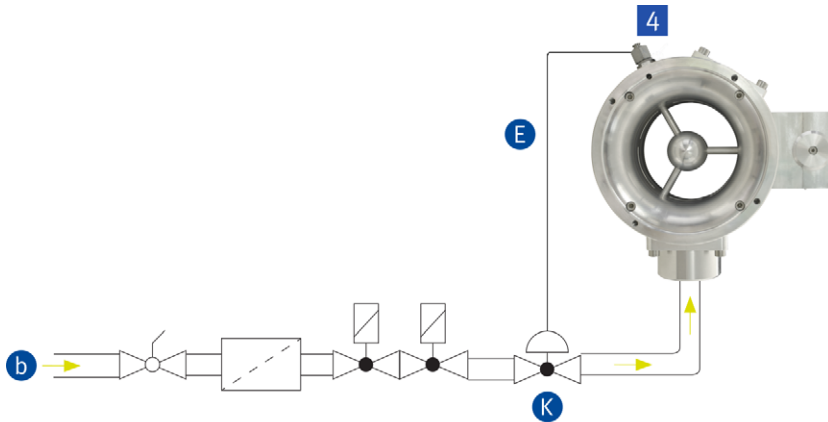

Pos.	Description
4	Impulse line connection
E	Impulse line
K	Balance/Zero pressure regulator
b	Gas

5.2.1 Install Flow Body



Explosion hazard! Risk of destruction!

The self-locking nut of the flow body secures itself against loosening by buckling a plastic ring in the slot of the nut by force-fit after tightening. If the self-locking nut is loosened, the plastic ring buckles again, so that the nut can no longer be securely tightened. If the flow body were to fall apart due to the use of a no longer securable nut, parts of the system will be destroyed and it could cause an explosion.

For the safe operation of the VariFuel2/2+, observe the following guidelines:

- The self-locking nut is pre-mounted on unused MOTORTECH flow bodies. For installation, the self-locking nut may be removed one time, and then used only one time for secure attachment.
- Under no circumstances may the used self-locking nut be used again in the event of flow body replacement.

5 Installation Instructions

To install or replace the flow body, free access must be provided at the VariFuel2/2+ both on the air inlet and on the mixture outlet.

Proceed as follows:

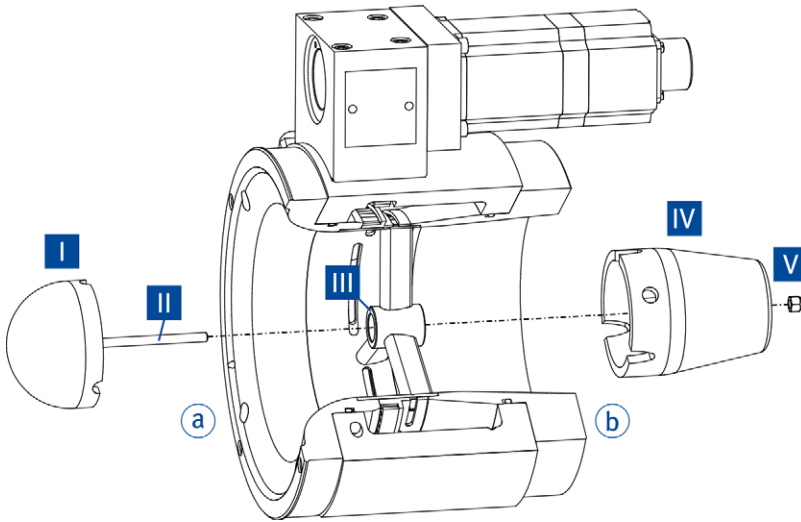

Illustration example

1. A label is enclosed with the flow body. Stick this label onto the field *Label Flow Body Size* of the VariFuel2/2+ nameplate. So you can determine the flow body size if the gas mixer is installed.



**Flow Body
Size XX,X mm**

5 Installation Instructions



2. First, completely disassemble the flow body by unscrewing the self-locking nut **V** and disconnecting the two body halves **I** **IV**.
3. To install the flow body, first slide the round half **I** over the central nozzle ring **III** on the air inlet side **(a)**. Note that the smallest flow body (\varnothing 23 mm/0.9") cannot be put on the central nozzle ring, but must be put in front of it.
4. On the mixture outlet side **(b)**, put the second half of the flow body **IV** over the threaded rod **II** of the first half and the central nozzle ring **III**.
5. Secure the threaded rod **II** with the self-locking nut **V**. Apply the adequate torque:
 - Flow bodies made of aluminum: 5 Nm (3.7 lb-ft)
 - Flow bodies made of thermoplastic material: 3 Nm (2.2 lb-ft)

5.2.2 Install VariFuel2/2+ into Intake Section

The mounting position of the VariFuel2/2+ gas mixer is arbitrary. For mounting, use the four threaded holes and the flat surface on the bottom side of the device.

The following must be observed during installation:

- The VariFuel2/2+ must be mounted tension-free, i.e. all bores of the flanges must be aligned with the housing bores.
- For the mixture outlet, consider the additional depth of the engine-specific mounting flange.
- With series 300 and 350, you can mount ring eyelets for lifting the VariFuel2/2+ into the provided threaded holes, if necessary.
- For the air inlet, gas inlet and mixture outlet, use only galvanized hexagon bolts.
- Tighten the screws firmly enough so that all connections are gas-tight. Use a suitable torque that matches the strength of the screw.
- Ensure that the inspection window on the fuel ring **7** remains freely accessible and is for example not covered by a pipe.
- Take care that the inspection window on the drive belt **6** remains easily available for checking and setting the belt tension.
- During installation, make sure that no loose parts get into the VariFuel2/2+.

5 Installation Instructions

Generally, you need to connect the following ports:

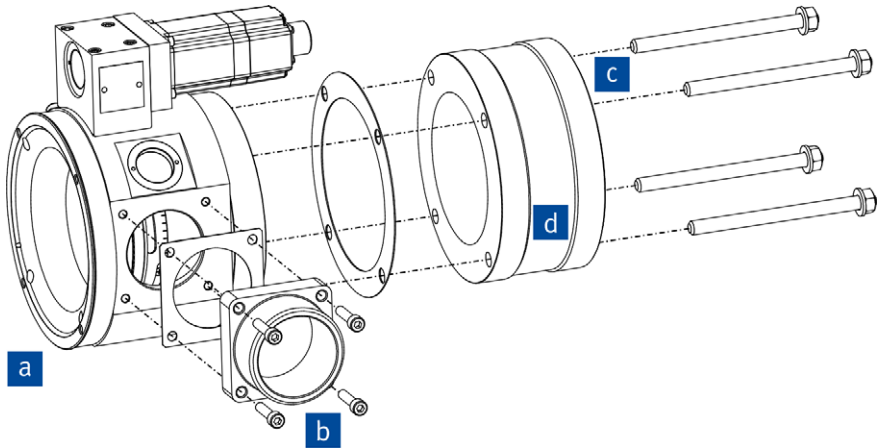

Illustration example



Explosion hazard!

If the system is not entirely tight and sealed, the combustible gas mixture may escape and result in an explosion hazard. Therefore, all ports and connections must be gas-tight. Use suitable clean seals and connecting materials.



Risk of injury!

When connecting the cables, your fingers may get stuck. For this reason, under no circumstances should you reach into the openings and gaps of the VariFuel2/2+ gas mixer when connecting the lines.

- Air inlet **a**
Hose connection (e.g. with clamp, seal and counter flange)
- Gas inlet **b**
Flexible gas line connection via a mounting flange. It is particularly important that the gas line is flexible if the gas mixer is rigidly coupled with the engine. Two gas connections (**2** **8**) are available. If required, the cover can be modified accordingly. For two-gas operation another adapter must be ordered in order to be able to use both gas connections simultaneously.

5 Installation Instructions



- **Mixture outlet** **c**
Connection via a bolt hole circle for engine specific mounting flange **d** (available with clamp, seal and counter flange)
- **Impulse line connection** **4**
Connection for the impulse line of the balance or zero pressure regulator for connection to the air inlet of the VariFuel2/2+ (cutting-ring connection). For optimum performance in accordance with its design, the VariFuel2/2+ must be operated with a balance or zero pressure regulator (see section *Assembly* on page 29). The connection is suitable for hoses with an outer diameter of 10 mm (0.4").
- **Optional: Gauge port** **3**
Connection for the measuring lead of a pressure gauge to measure the gas pressure at the gas inlet of the VariFuel2/2+. The connection is suitable for hoses with an inner diameter of 8 mm (0.31").

5.2.3 Connect Stepper Motor Driver



Risk of destruction!

To rule out the possibility of moving the connected VariFuel2/2+ out of the control area, observe the following procedure when connecting the stepper motor to the VariStep3 stepper motor driver:

1. Configure the VariStep3 stepper motor driver for the desired VariFuel2/2+ gas mixer (see section *External Device* in the operating manual of the VariStep3 stepper motor driver).
2. Disconnect the VariStep3 stepper motor driver from the power supply.
3. Connect the stepper motor of the VariFuel2/2+ gas mixer to the stepper motor driver.
4. Connect the VariStep3 stepper motor driver again to the power supply.
 - ▶ The VariStep3 stepper motor driver initiates a reference run. The VariStep3 stepper motor driver is ready for operation.

To connect the VariStep3 stepper motor driver to the stepper motor **1** of the VariFuel2/2+, read the operating manual of the VariStep3 stepper motor driver.

6 Operation

6.1 Start-up



Explosion hazard!

If the system is not entirely tight and sealed, the combustible gas mixture may escape and result in an explosion hazard. Always check the tightness of the system before start-up. Upon completion of your works, make sure that you close the gauge port on the VariFuel2/2+.



Operational safety!

Contaminated gas can lead to blocking of the fuel ring and thus can cause the gas engine to stop. Examine the VariFuel2/2+ regularly for contamination as a part of the regular maintenance intervals customary for your system. Use clean gas preferably.

Basic Settings of the System

With an ideal design, the VariFuel2/2+ gas mixer is operated in a range between 15 % and 80 % of the fuel ring's opening. In this way the prescribed emission values should be complied with at nominal load. For the engine start, additionally specify a suitable start position in the master control.

The VariFuel2/2+ gas mixer is a Venturi mixer. For optimum performance according to its design, it is important that air pressure and gas pressure are equal, so that the gas is sucked in by the Venturi effect alone. Therefore, operate the VariFuel2/2+ gas mixer solely with a balance or zero pressure regulator connected to the air inlet of the VariFuel2/2+ via the impulse line connection of the VariFuel2/2+. Also, adjust the balance/zero pressure regulator in such a way that the balance/zero pressure regulator equalizes the gas pressure with the air pressure. Otherwise, if the connection or adjustment is incorrect, the gas will be forced into the gas mixer and not sucked in alone, which can lead to a performance loss.

Problems When Starting

Often the gas engine's problem is its starting performance. With the starting speed the air speed in the gas mixer is very low, which will cause very low suction pressure at the gas inlet. This can lead to not enough gas being sucked into the engine to make the mixture ignite. The following procedures may be helpful:

- MOTORTECH recommends to start with an opening of the fuel ring of 30 % to 35 %. If the engine does not start, open the fuel ring in steps of 1 to 2 %.
- For gases with low fuel value, it may be necessary to set the balance/zero pressure regulator to a slight overpressure (max. 5 mbar for starter speed) for the engine start phase. Do not set the overpressure too high, because too much gas content in the engine can lead to start problems. As soon as the engine is running, set the balance/zero pressure regulator back to pressure balance in idle at nominal speed. This setting guarantees that adequate suction pressure exists at the gas inlet at engine start.

- Other reasons may be that, for example, the nominal diameter of the flexible gas line is smaller than that of the gas mounting flange or the diameter of the gas mounting flange is too small to discharge sufficient gas into the engine at low suction pressure. Check in any case whether the gas supply of your VariFuel2/2+ gas mixer is sufficiently dimensioned. If you have any questions, contact MOTORTECH (see *Customer Service Information* on page 46).

Engine Does Not Reach Nominal Power

With the prescribed emissions, the engine does not reach its nominal output. The following scenarios might be possible:

Scenario 1:

- The opening of the fuel ring is in the range between 15 % and 80 %.
- The nominal output is reached by enriching the mixture.
- At the gauge port of the VariFuel2/2+, an underpressure greater than 30 mbar is measured.

In this case, it is necessary to increase the air supply. This can be achieved based on the following measures:

- Check air filter for dirt or excessive back pressure. Clean or replace air filter if necessary.
- Check underpressure in the air intake line (standard value: –5 mbar to –25 mbar)
- Install a smaller flow body. To do so, please contact MOTORTECH (see *Customer Service Information* on page 46).

Scenario 2:

- The opening of the fuel ring is > 95 %
- The nominal output is not reached by enriching the mixture.
- An underpressure less than 60 mbar is measured at the gauge port of the VariFuel2/2+.

In this case, it is necessary to increase the gas supply. This can be achieved by carrying out one of the following measures:

- Install larger flow body
- Use larger gas mounting flange.

To do so, please contact MOTORTECH (see *Customer Service Information* on page 46).

7 Errors

7.1 Special Tools for Troubleshooting

Special tools have been developed at MOTORTECH which are needed to carry out certain work safely and conveniently for the maintenance and repair of VariFuel2/2+ gas mixers. The following tools can be obtained from MOTORTECH:

- **VariFuel Locking Tool for Toothed Pulley**
With this tool, you lock the toothed pulley of a VariFuel2/2+ gas mixer to tighten or loosen the hexagon socket head cap screw with which the toothed pulley is attached to the shaft.
- **VariFuel Tool for Inspection Window**
You use the VariFuel Tool for Inspection Window to mount and dismount the inspection window on the upper part of the VariFuel2/2+ housing.
- **VariFuel Adjustment Tool for Belt Tension**
The VariFuel Adjustment Tool for Belt Tension is ideal for adjusting the tension of the drive belt of a VariFuel2/2+ air/gas mixer.

The tools are supplied with brief operating instructions, which must be taken into account during use.

7.2 Possible Faults



Explosion hazard!

If the system is not entirely tight and sealed, the combustible gas mixture may escape and result in an explosion hazard.

The device's tightness is checked and guaranteed by MOTORTECH after production.

If the device is opened by the customer for installation or maintenance purposes, the customer is responsible for restoring the system's leak tightness.

If the customer cannot guarantee this, the device must not be opened and must be replaced and returned to MOTORTECH to remedy any failures.

Troubleshooting

Problem	Possible cause	Solution
Movement of the fuel ring lags.	Belt tension is too low.	Adjust belt tension with the VariFuel Adjustment Tool for Belt Tension and adjust the fuel ring (see <i>Adjust Fuel Ring</i> on page 44).
	Stepper motor is defective.	Replace the stepper motor. For this operation, you need special repair kits from MOTORTECH.
Fuel ring does not move.	Fuel ring is dirty.	Disassemble and clean the VariFuel2/2+ and replace all wearing parts. For this operation, you need special repair kits from MOTORTECH.
	Influence of master control	Check the master control.
	Shaft has loosened from the stepper motor.	Tighten the shaft with the set screw (see <i>Fix Shaft</i> on page 41). Upon completion, check if the system is properly sealed!
	Stepper motor is defective.	Replace the stepper motor. For this operation, you need special repair kits from MOTORTECH.
	Stepper motor driver is in error mode.	Confirm all error messages.
	Stepper motor driver is incorrectly configured.	Configure your VariStep3 stepper motor driver via the MICT. Afterwards if necessary adjust the fuel ring (see <i>Adjust Fuel Ring</i> on page 44).
	Stepper motor driver is unsuitable.	Use a compatible stepper motor driver.
	Wiring of stepper motor and/or stepper motor driver is defective.	Check the wiring and make sure that the supply voltage is available.
	The toothed pulley has detached itself from the shaft of the stepper motor.	Fix the toothed pulley with the VariFuel Locking Tool for Toothed Pulley and adjust the fuel ring (see <i>Adjust Fuel Ring</i> on page 44).
	Belt tension is too high.	Adjust belt tension with the VariFuel Adjustment Tool for Belt Tension and adjust the fuel ring (see <i>Adjust Fuel Ring</i> on page 44).

7 Errors

Problem	Possible cause	Solution
Traverse range of the fuel ring corresponds to the size of one opening in the fuel ring. However, the location of the movement is wrong.	Incorrect adjustment of the fuel ring.	See <i>Adjust Fuel Ring</i> on page 44
Traverse range of the fuel ring is too small/too big.	A wrong VariFuel2/2+ is configured in the stepper motor driver.	Configure your VariStep3 stepper motor driver via the MICT. Afterwards if necessary adjust the fuel ring (see <i>Adjust Fuel Ring</i> on page 44).
Fuel ring scale is not in the inspection window.	Home position lost.	See <i>Adjust Fuel Ring</i> on page 44
POWER-LED of the stepper motor driver does not light up although it is connected to the supply voltage.	Stepper motor driver is defective.	Replace the stepper motor driver.
Stepper motor does not move without interruptions.	There is no malfunction. When the air/fuel ratio is correct, the motor remains in its position.	

7.3 Fix Shaft

All graphics used in this section represent an example of a VariFuel2/2+ series 200-120.

To fix the shaft between stepper motor and VariFuel2/2+, the stepper motor must be completely dismantled. The explosion view provides information on how the stepper motor has been installed.

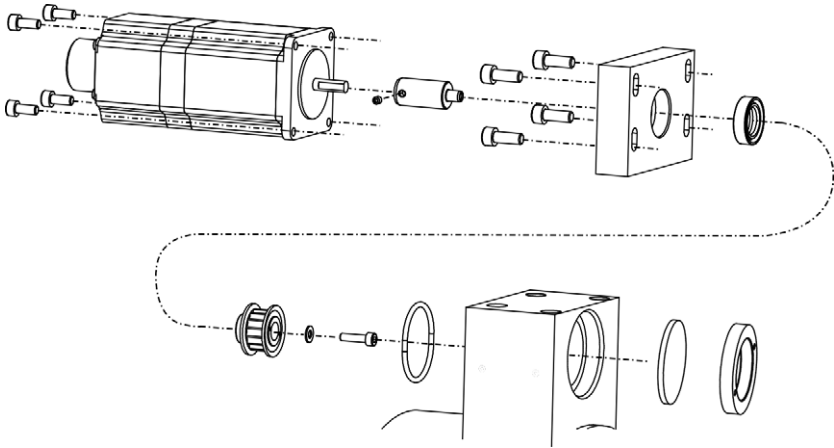

Dismounting

1. Remove the inspection window in the upper part of the housing with the VariFuel Tool for Inspection Window. For this purpose read the instructions of the VariFuel Tool for Inspection Window.
2. Remove the adapter plate with the stepper motor as well as the O-ring from the housing of the VariFuel2/2+.
3. Disconnect the toothed pulley from the shaft of the stepper motor.
4. Remove the adapter plate from the stepper motor.
5. Loosen the set screw from the shaft.

7 Errors

Installation

1. Moisten the set screw **1** with thread lock fluid.
2. Replace the shaft **2** on the axis of the stepper motor **3** and tighten the set screw with the torque stated in the following drawing.



Alignment and positioning of the shaft

Observe the following while positioning the shaft.

- The drill hole in the shaft must be aligned with the flattening of the axle.
- The shaft must be 1 mm from the stepper motor.

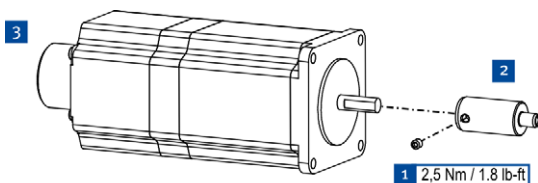

3. Moisten the shaft seal ring **4** with silicone spray.
4. Press the shaft seal ring **4** with the flat side first into the adapter plate.

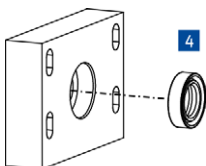

5. Moisten the hexagon socket head cap screws M5x12 **5** with thread lock fluid.

- Screw the adapter plate to the stepper motor and place the toothed pulley **6** on the shaft.



Observe alignment of the adapter plate and the stepper motor

Align the adapter plate as shown in the illustrations.

When aligning the stepper motor, observe the guide nose in the stepper motor connection plug. Align the stepper motor so that you can connect the wiring harness optimally to the stepper motor.

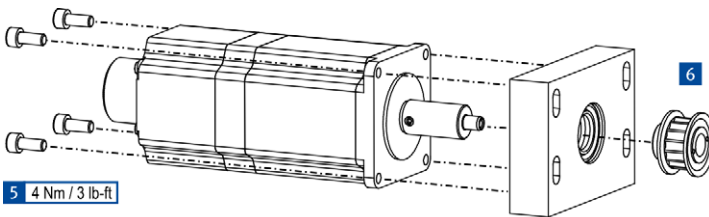

- Attach the toothed pulley with the washer **7** and the hexagon socket head cap screw M4x16 **8** to the shaft of the stepper motor.



Do not tighten the screw

Do not tighten the hexagon socket head cap screw M4x16 **8**. The toothed pulley must be rotatably mounted on the shaft to allow the fuel ring to be adjusted.

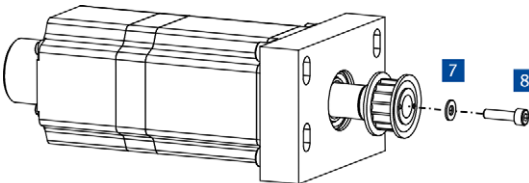

- Insert the O-ring **9** into the housing of the VariFuel2/2+.

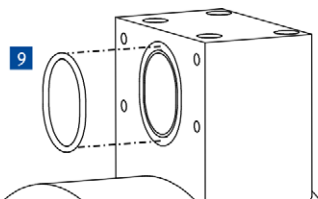

7 Errors

- Attach the stepper motor with the hexagon socket head cap screws M6x16 ¹⁰ of the adapter plate to the VariFuel2/2+.



Do not tighten the screws

Do not tighten the hexagon socket head cap screw M6x16 ¹⁰. The stepper motor has to remain movable to enable the correct belt tension to be set.

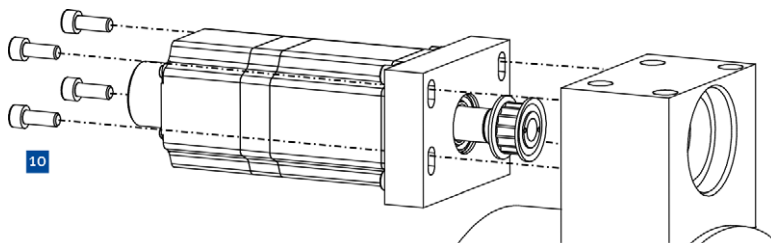

- Tighten the drive belt with the VariFuel Adjustment Tool for Belt Tension as described in the supplied instructions for use.
 - The stepper motor has been installed. You can continue with the adjustment of the fuel ring (see *Adjust Fuel Ring* on page 44).

7.4 Adjust Fuel Ring

In order to adjust the fuel ring, the VariFuel2/2+ must be connected with the VariStep3 stepper motor driver. Adjust the fuel ring as follows:

- Stop the gas supply.
- Remove the inspection window from the upper part of the housing with the VariFuel Tool for Inspection Window. Proceed as described in the instructions for use of the inspection window tool.

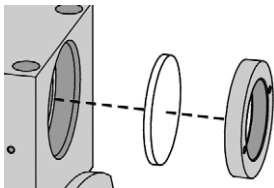

- In the upper part of the housing, loosen the toothed pulley with the VariFuel Locking Tool for Toothed Pulley and a hex key SW3. Proceed as described in the instructions for use of the locking tool. After loosening, keep the locking tool inserted in the toothed pulley.

4. If not already done, connect the stepper motor to the VariStep3 stepper motor driver. For this purpose, read the VariStep3 operating manual.
5. Move the stepper motor into the closed position.
6. Rotate the reference scale of the fuel ring into the lateral inspection window of the VariFuel2/2+ by moving the fuel ring via the VariFuel locking tool that has been inserted into the toothed pulley in step 3. Adjust the closed position of the fuel ring in this way so that the reference marking **A** points to the uppermost line **B** of the reference scale. After adjusting, keep the locking tool inserted in the toothed pulley.

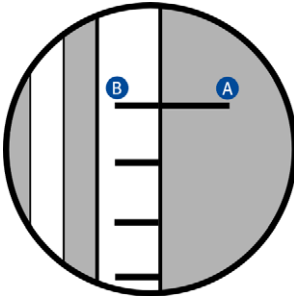

7. Fasten the toothed pulley to the shaft with the hexagon socket head cap screw M4x16, a hex key SW3 and the VariFuel Locking Tool for Toothed Pulley as described in the locking tool instructions for use. Use a tightening torque of 2.5 Nm (1.9 lb-ft).



Conduct in the event of an error message

If you move the stepper motor while tightening the screw, you will get an error message from the VariStep3 stepper motor driver. Confirm this via the MICT.

8. Initiate a reference run with the VariStep3 stepper motor driver.
 - ▶ The fuel ring has been adjusted and the stepper motor approaches all positions correctly again.
9. Close the inspection window in the upper part of the housing with the VariFuel Tool for Inspection Window.

7 Errors

7.5 Customer Service Information

You can reach our customer service during business hours at the following phone and fax number, or by email:

Phone: +49 5141 93 99 0

Fax: +49 5141 93 99 99

Email: service@motortech.de

7.6 Returning Equipment for Repair / Inspection

To return the device for repair and inspection, obtain a return form from your MOTORTECH contact person (see *Customer Service Information* on page 46).

After you have completely filled out the return form and returned it to MOTORTECH, MOTORTECH will send you back the return form and a delivery note with RMA number specified. Enclose the return form with your device and attach the delivery note to the packaging so that it is clearly visible from the outside. This will ensure a speedy and smooth processing of your repair order.

Send the device with delivery note and return form to one of the two addresses below or to the nearest MOTORTECH representative:

MOTORTECH GmbH

Hogrevestr. 21–23
29223 Celle

Germany

Phone: +49 5141 93 99 0

Fax: +49 5141 93 99 98

www.motortech.de

motortech@motortech.de

MOTORTECH Americas, LLC

1400 Dealers Avenue, Suite A
New Orleans, LA 70123

USA

Phone: +1 504 355 4212

Fax: +1 504 355 4217

www.motortechamericas.com

info@motortechamericas.com

7.7 Instructions for Packaging the Equipment

For return shipment, equipment should be packaged as follows:

- Use packaging material that does not damage the equipment surfaces.
- Wrap the equipment with sturdy materials and stabilize it inside the packaging.
- Use sturdy adhesive film to seal the packaging.

8.1 Maintenance Instructions



Explosion hazard!

If the system is not entirely tight and sealed, the combustible gas mixture may escape and result in an explosion hazard.

The device's tightness is checked and guaranteed by MOTORTECH after production.

If the device is opened by the customer for installation or maintenance purposes, the customer is responsible for restoring the system's leak tightness.

If the customer cannot guarantee this, the device must not be opened and must be replaced and returned to MOTORTECH to remedy any failures.

Observe the following maintenance instructions:

- A visual inspection of the gas mixer must be carried out every time the engine is serviced within the normal service intervals of your system. The visual inspection includes:
 - Checking the fuel ring for dirt. For having the VariFuel2/2+ cleaned, contact your MOTORTECH contact person (see *Customer Service Information* on page 46).
 - Checking the drive belt for signs of material fatigue (e.g. cracks)
- MOTORTECH offers cleaning, for this purpose send in your gas mixer (see *Returning Equipment for Repair / Inspection* on page 46).
- All maintenance works which require opening the VariFuel2/2+ (such as adjusting the fuel ring) must only be carried out by personnel trained by MOTORTECH.
- Dirty seals (e.g. flat gaskets, O-rings) can lead to leakage of the VariFuel2/2+. When replacing seals, only use clean seals from MOTORTECH (part of MOTORTECH repair kits).
- Spare parts (e.g. drive belt, fuel ring) are available from MOTORTECH as repair kits. Always use these repair kits, otherwise a proper functionality cannot be guaranteed.
- If a safe repair cannot be carried out, since the gas tightness cannot be tested for example, the device must be returned to MOTORTECH (see *Returning Equipment for Repair / Inspection* on page 46). If needed, a replacement or exchange device can be provided. For this purpose, contact your MOTORTECH contact person (see *Customer Service Information* on page 46).

8.2 Spare Parts and Accessories

For spare parts and accessories, please refer to our current Product Guide, which is available for you to download on the internet at www.motortech.de.

9 Index

A	
Abbreviation	6
Accessories	38, 47
Application	13
Assembly.....	29
B	
Balance pressure regulator	
Connect.....	33
Start-up.....	36
D	
Declaration of conformity	15
Declaration of incorporation	15
Design.....	19
Dimensions	19
Disposal.....	10
E	
Encoder.....	26, 27
Errors	38
F	
Flow body	
Install.....	29
Fuel ring	
Adjust.....	44
Fuel value	13
Function	11
M	
Mechanical data.....	16
MOTORTECH	
Address.....	46
P	
Part number.....	18
R	
Regulations	15
Repair	46
Return shipment	46
S	
Scope of supply.....	28
Serial number	18
Starting performance.....	36
Start-up	36
Stepper motor	
Connect	35
Connector	26
Electrical data	27
System configuration	36
T	
Tools	38
Z	
Zero point calibration	44
Zero pressure regulator	
Connect	33
Start-up	36

MOTORTECH GmbH

Hogrevestr. 21–23
29223 Celle
Germany

Phone: +49 (5141) 93 99 0
Fax: +49 (5141) 93 99 99
E-Mail: sales@motortech.de
Web: www.motortech.de

MOTORTECH Americas, LLC

1400 Dealers Avenue, Suite A
New Orleans, LA 70123
USA

Phone: +1 (504) 355 4212
Fax: +1 (504) 355 4217
E-Mail: info@motortechamericas.com
Web: www.motortechamericas.com

MOTORTECH Shanghai Co. Ltd.

Room 1018 Enterprise Square,
No. 228 Meiyuan Road,
Jing'An District, 200070 Shanghai
China

Phone: +86 (21) 6380 7338
E-Mail: info@motortechshanghai.com
Web: www.motortechshanghai.com

GAS ENGINE TECHNOLOGY

Ignition Systems	Red
Spark Plugs & Accessories	Orange
Gas Engine Control Systems	Light Blue
Sensor Systems	Yellow
Air/Fuel Ration Control Systems	Green
Exhaust Gas Aftertreatment	Green
Gas Engine Accessories	Grey