

# MOTORTECH

## High Performance Spark Plugs



**MHP-Plugs**   
MOTORTECH HIGH PERFORMANCE SPARK PLUGS

## MOTORTECH High Performance Spark Plugs

The expansion of MOTORTECH's state-of-the-art ignition controllers is driven by the latest developments of modern spark ignited gas engines. The operation of these high performance engines with advanced compression rates and very efficient lean-burn combustion systems require much higher voltages to allow a perfect and effective combustion.

MHP spark plugs are designed to meet the requirements, both of modern and common engine developments and reliably deliver highest voltages and thus a strong spark down into the combustion chamber. The J-type electrode design with IRIIDIUM alloy discs on center and ground electrode provides reliable combustion and increased spark plug life and helps to reduce service costs due less spark plug changes.

### General Features

- Hot lock technology ensures increased spark plug durability even in high compression engines
- J-type electrode design for enhanced combustion
- Supplies even highest voltages of modern ignition systems like MOTORTECH's MIC series
- Long design insulators for best flashover protection
- Advanced spark erosion resistance
- Suppression of electromagnetic interference (EMI)
- Less spark plug changes reduce operation costs
- Available with different thread sizes and reaches

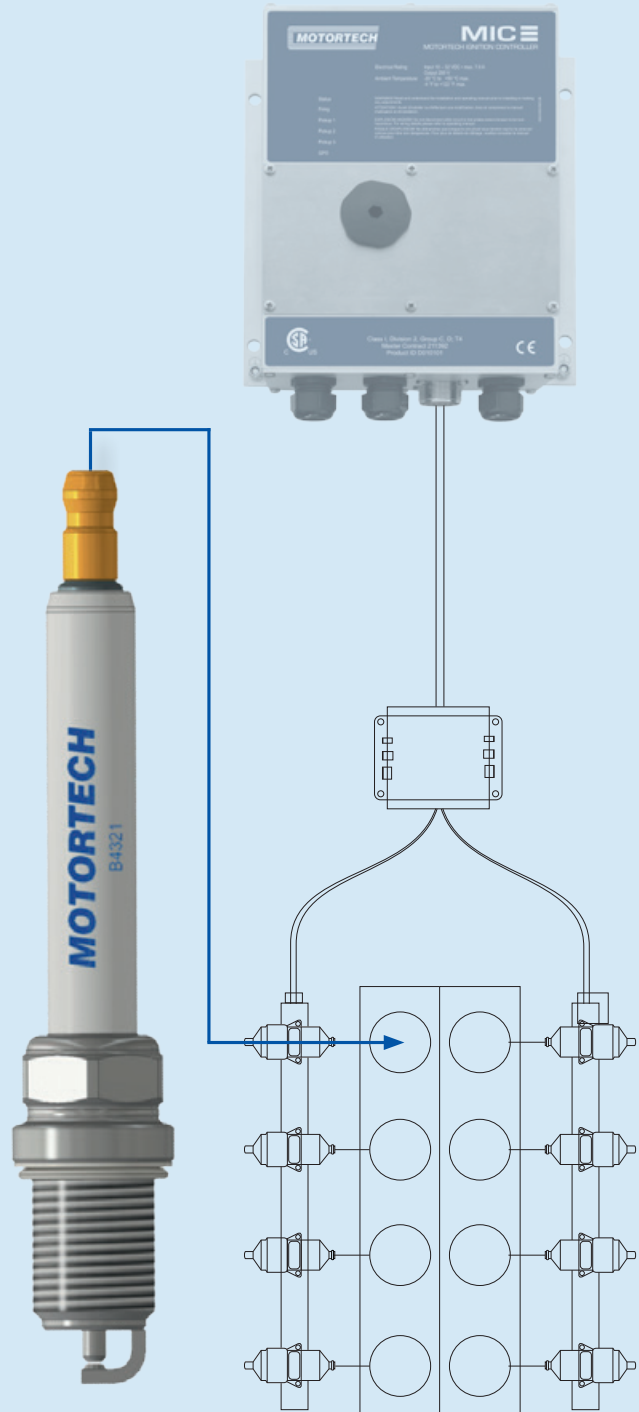

## Key Design Features

- 1 Removable threaded brass SAE terminal
- 2 Long aluminum oxide ceramic insulator offers best flashover protection, especially in combination with PolyMot™ spark plug leads and extensions
- 3 Integrated stress resistant monolithic resistor suppresses electromagnetic interference (EMI)
- 4 Unified hex size reduces amount of required service tools for installation
- 5 J-type electrode design and use of higher erosion resistance materials ensure better combustion particularly on lean burn gas engines and longest service life
- 6 Copper cored center electrode with laser welded IRIDIUM alloy disc
- 7 Copper cored ground electrode with laser welded IRIDIUM alloy disc

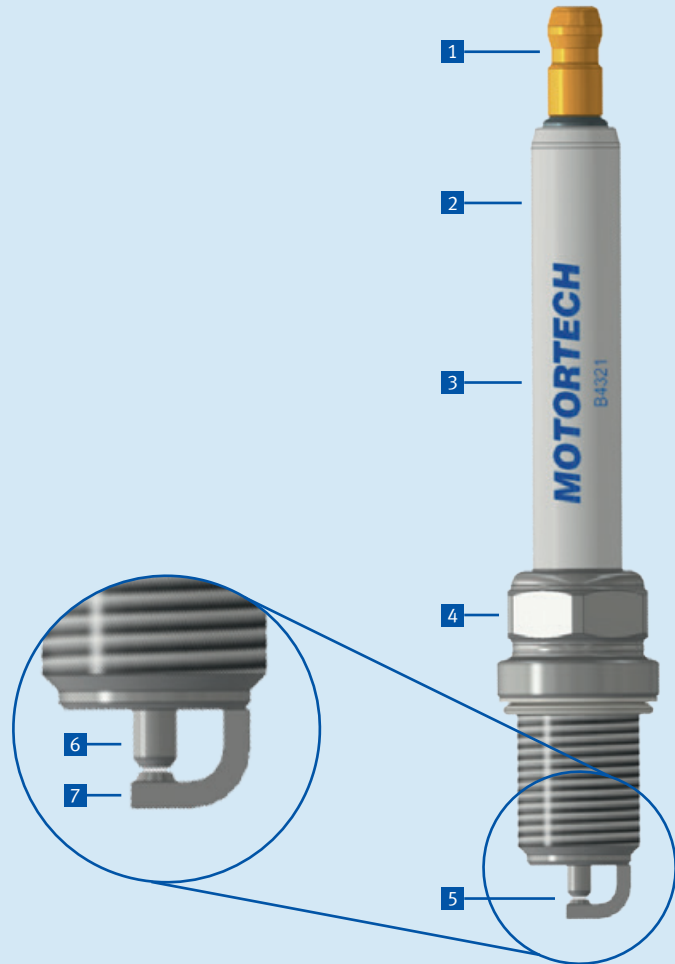

## Spark Plug Types

Thread Size	Type	Thread Reach	Hex Size	Electrode Design
M14x1.25	B4321	0.750 in. (19.0 mm)	5/8 in. (16.0 mm)	J-type (Ir/Ir)
M18x1.5	B8124	0.500 in. (12.7 mm)	13/16 in. (20.8 mm)	J-type (Ir/Ir)
	B8324	0.750 in. (19.0 mm)		
	B8524	1.000 in. (25.4 mm)		
M22x1.5	B2224	0.600 in. (15.0 mm)	13/16 in. (20.8 mm)	J-type (Ir/Ir)
	B2324	0.750 in. (19.0 mm)		
	B2424	0.875 in. (22.2 mm)		
7/8-18 UNS	B7224	0.600 in. (15.0 mm)	13/16 in. (20.8 mm)	J-type (Ir/Ir)
	B7324	0.750 in. (19.0 mm)		
	B7424	0.875 in. (22.2 mm)		

# M14x1.25

B4321

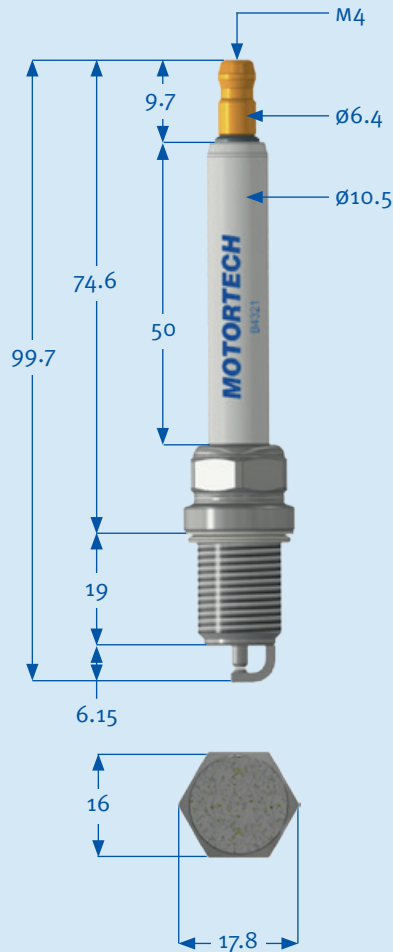

Dimensions in mm

Type	Thread Size	Thread Reach	Electrode Design	Alloy Center / Ground Electrode	Hex Size	Electrode Gap	Tightening Torque <sup>1)</sup>
B4321	M14x1.25	0.750 in. 19.0 mm	J-type	Ir/Ir	5/8 in. 16.0 mm	0.010 in. 0.25 mm	25 lb-ft 35 Nm

<sup>1)</sup> For cast iron cylinder heads. Please observe the tightening torques rendered by each engine manufacturer.

# M18x1.5

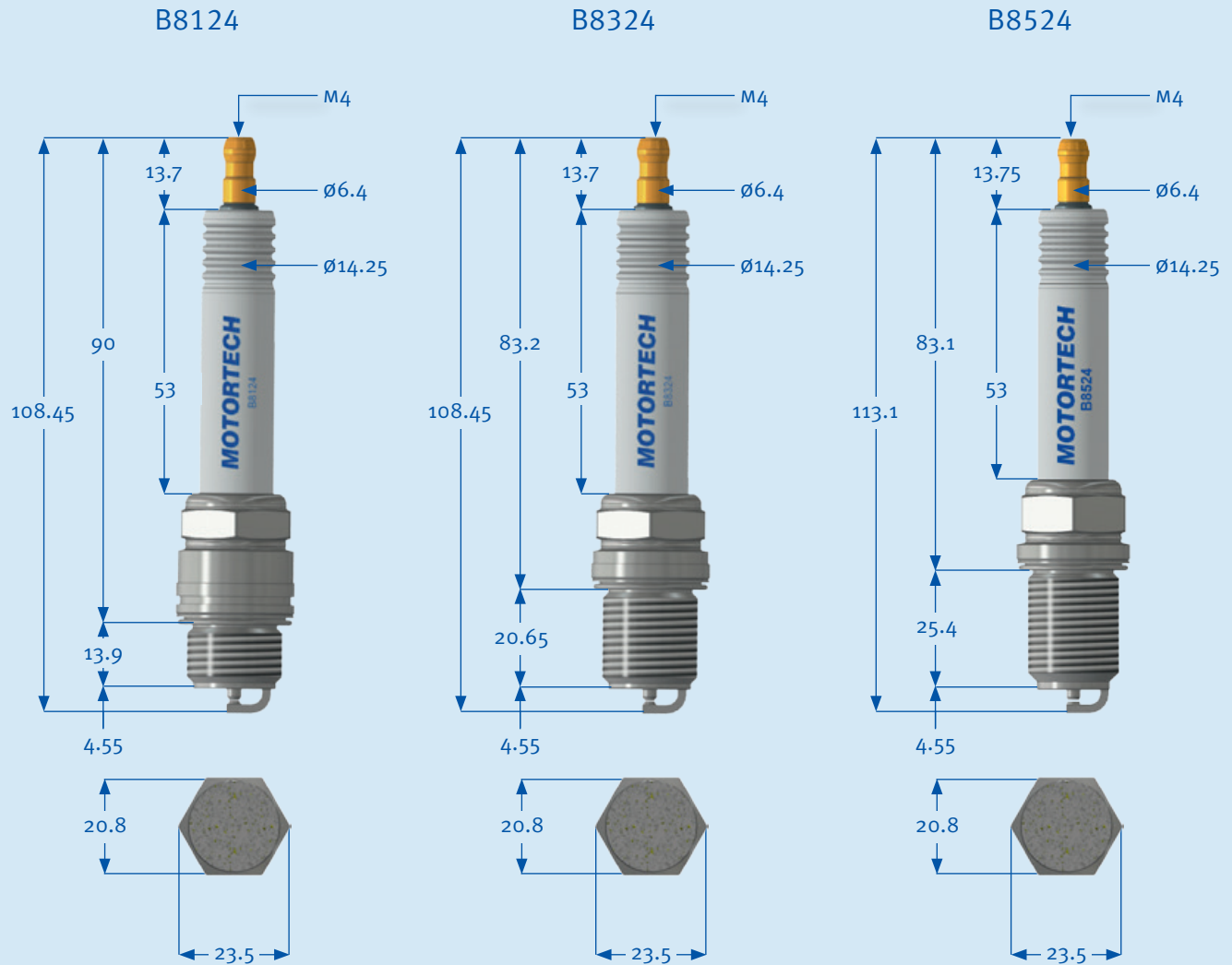

Dimensions in mm







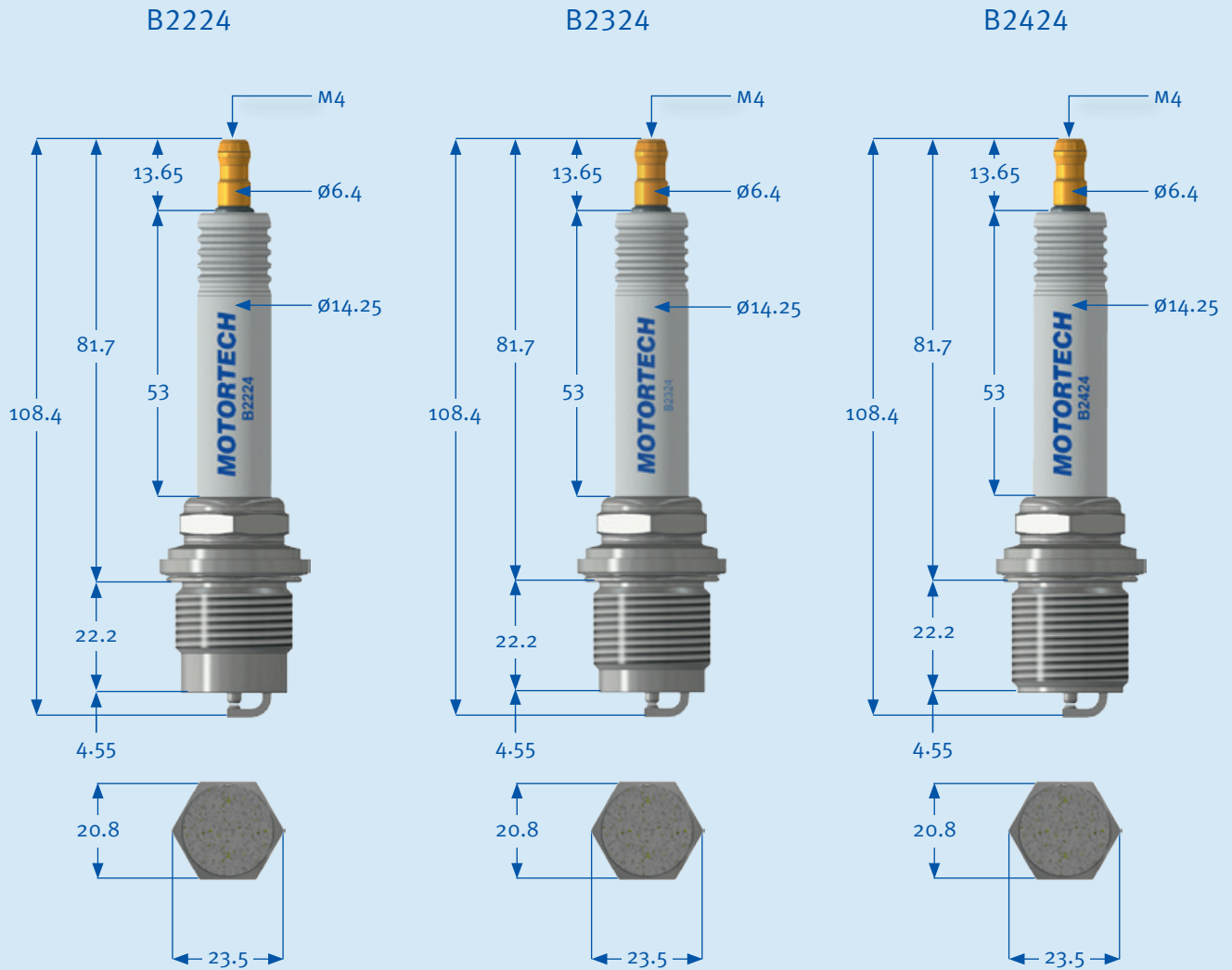

Type	Thread Size	Thread Reach	Electrode Design	Alloy Center / Ground Electrode	Hex Size	Electrode Gap	Tightening Torque <sup>1)</sup>
B8124	M18x1.5	0.500 in. 12.7 mm	J-type	Ir/Ir	13/16 in. 20.8 mm	0.010 in. 0.25 mm	36 lb-ft 50 Nm
B8324	M18x1.5	0.750 in. 19.0 mm	J-type	Ir/Ir	13/16 in. 20.8 mm	0.010 in. 0.25 mm	36 lb-ft 50 Nm
B8524	M18x1.5	1.000 in. 25.4 mm	J-type	Ir/Ir	13/16 in. 20.8 mm	0.010 in. 0.25 mm	36 lb-ft 50 Nm

<sup>1)</sup> For cast iron cylinder heads. Please observe the tightening torques rendered by each engine manufacturer.

# M22x1.5

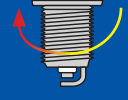

Dimensions in mm

Type	Thread Size	Thread Reach	Electrode Design	Alloy Center / Ground Electrode	Hex Size	Electrode Gap	Tightening Torque <sup>1)</sup>
B2224	M22x1.5	0.600 in. 15.0 mm		Ir/Ir	 13/16 in. 20.8 mm	 0.010 in. 0.25 mm	51 lb-ft, 70 Nm
B2324	M22x1.5	0.750 in. 19.0 mm		Ir/Ir	 13/16 in. 20.8 mm	 0.010 in. 0.25 mm	51 lb-ft, 70 Nm
B2424	M22x1.5	0.875 in. 22.2 mm		Ir/Ir	 13/16 in. 20.8 mm	 0.010 in. 0.25 mm	51 lb-ft, 70 Nm

<sup>1)</sup> For cast iron cylinder heads. Please observe the tightening torques rendered by each engine manufacturer.

# 7/8-18 UNS



B7224

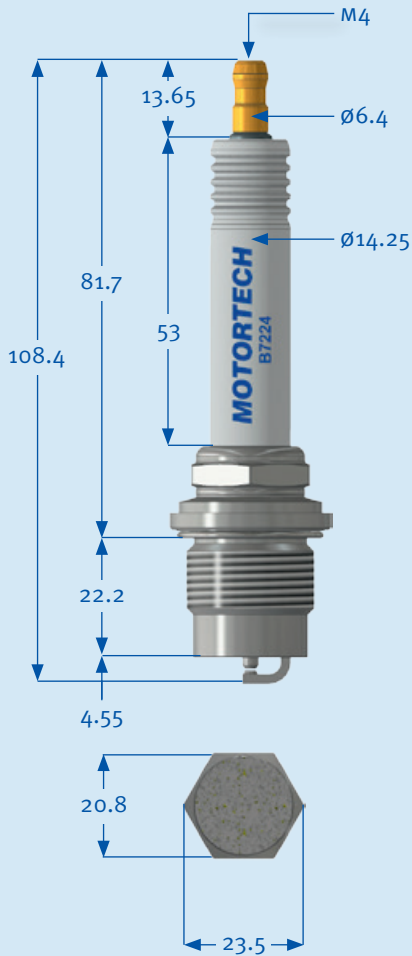

B7324

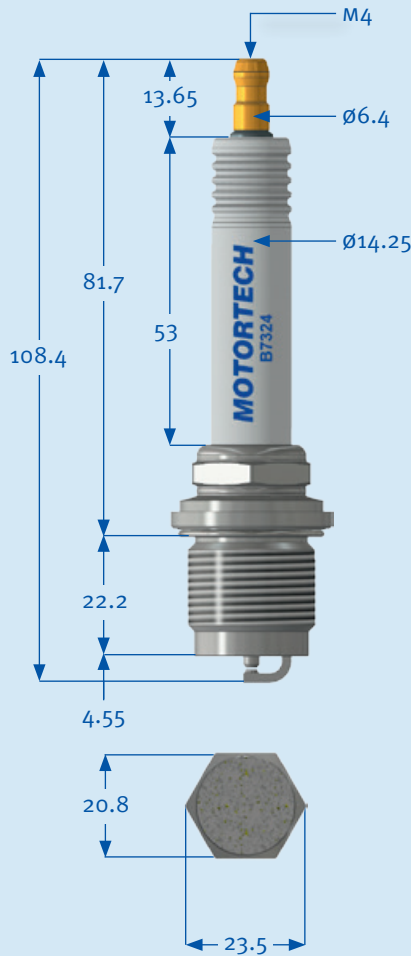

B7424

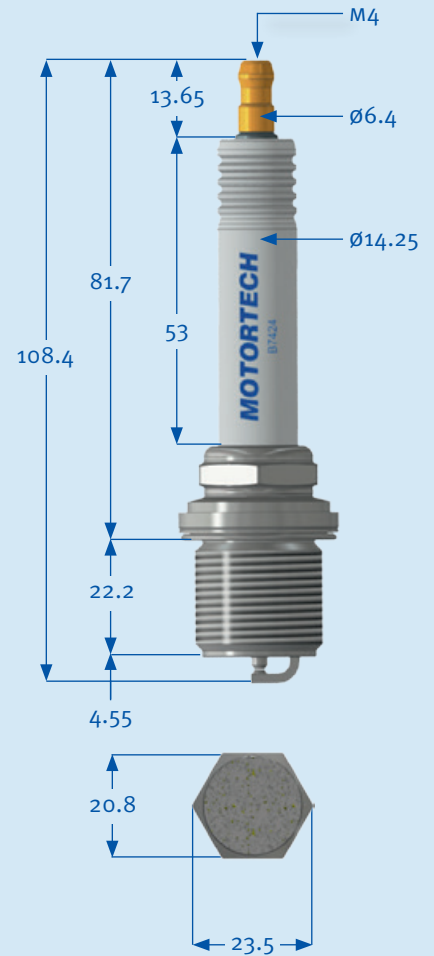

Dimensions in mm

Type	Thread Size	Thread Reach	Electrode Design	Alloy Center / Ground Electrode	Hex Size	Electrode Gap	Tightening Torque <sup>1)</sup>
B7224	7/8-18 UNS	0.600 in. 15.0 mm	J-type	Ir/Ir	13/16 in. 20.8 mm	0.010 in. 0.25 mm	51 lb-ft 70 Nm
B7324	7/8-18 UNS	0.750 in. 19.0 mm	J-type	Ir/Ir	13/16 in. 20.8 mm	0.010 in. 0.25 mm	51 lb-ft 70 Nm
B7424	7/8-18 UNS	0.875 in. 22.2 mm	J-type	Ir/Ir	13/16 in. 20.8 mm	0.010 in. 0.25 mm	51 lb-ft 70 Nm

<sup>1)</sup> For cast iron cylinder heads. Please observe the tightening torques rendered by each engine manufacturer.

## Cross References

ALTRONIC®		MOTORTECH	NOTE
J1463DP		B4321	1)/(2)
L1843B		B8124	1)
L1843IP		B8124	1)
L1863B		B8324	1)
L1863DP		B8324	1)
L1863IP		B8324	1)
L2252B		B7224	1)
L2252DP		B7224	1)
L2252IP		B7224	1)
L2272B		B7424	1)
L2282B		B7424	1)
L2282IP		B7424	1)

BERU®		MOTORTECH	NOTE
14-3 CPU	Z102	B4321	1)/(2)
14FR-4DIU	Z212	B4321	2)
14FR-4DIU02	Z328	B4321	2)
14FR-4DIU3	Z290	B4321	2)
14FR-4DPUO	Z189	B4321	2)
14GZ6-77-2	Z244	B4321	
14GZ-LL		B4321	1)/(2)
14GZ-LL2		B4321	1)/(2)
14GZ-LL-FR		B4321	2)
14R-3CPU	Z163	B4321	1)/(2)
14R-4CDP	Z147	B4321	1)/(2)
14R-4CDP	Z191	B4321	1)/(2)
14R-4CIU	Z187	B4321	1)/(2)
14R-4CIU2	Z215	B4321	1)/(2)
14R-4CIU2	Z276	B4321	1)/(2)
14R-4DIU2	Z258	B4321	1)/(2)
14R-4DIU2	Z259	B4321	1)/(2)
14R-4DIU3	Z281	B4321	1)/(2)
18GZ20	Z178	B8324	1)
18GZ22	Z182	B8124	1)
18GZ4-77	Z179	B8324	1)
18GZ5-77-2	Z201	B8324	
18GZ6-77-2	Z202	B8324	1)
18GZ7	Z168	B8324	1)
7/8GZ11	Z180	B7324	1)
7/8GZ9	Z181	B7224	1)
Blue Ignition	Z350SB	B8324	1)
Green Ignition	Z352SB	B8324	1)
Super Green Ign.	Z353SB	B8324	1)

BG®	MOTORTECH	NOTE
RB105-1	B7224	1)
RB114-1	B7424	1)
RB212-1	B7224	1)
RB485-1	B8124	1)
RB777-1	B8324	1)
RB777-2	B8324	1)
RB778-1	B8324	1)
RB778-2	B8324	1)

BOSCH®	MOTORTECH	NOTE
7302	B8324	1)
7303	B8124	1)
7305	B8324	1)
7306	B8324	1)
7307	B8324	
7308	B8324	
7311	B4321	1)/(2)
7313	B4321	1)/(2)
7315	B4321	1)/(2)
7321	B4321	2)
7322	B4321	2)

CATERPILLAR®	MOTORTECH	NOTE
194-8518	B8324	1)
243-4291	B8324	1)
2N2839	B4321	1)/(2)
306-6663	B8324	1)

CHAMPION®	MOTORTECH	NOTE
B86N	B8324	1)
C95F	B7224	1)
D14N	B8124	1)
D78Y	B8124	1)
D89D	B8124	1)
FB77WPCC	B8324	1)
KB75N	B8324	1)
KB77WPCC	B8324	1)
M82N	B8124	1)
RB75N	B8324	1)

1) Due to divergent hex sizes, use of suitable spark plug socket is necessary for installation of MHP-Plug.

2) MHP-Plug requires use of special spark plug lead due to longer ceramic insulator.



CHAMPION®	MOTORTECH	NOTE
RB75PP	B8324	1)
RB75WPCC	B8324	
RB76N	B8324	1)
RB76PP	B8324	1)
RB77CC	B8324	1)
RB77N	B8324	1)
RB77WPCC	B8324	1)
RC78PYP	B4321	2)
RC78PYP15	B4321	2)
RC78PYP17	B4321	2)
RC78PYP21	B4321	2)
RC78PYP25	B4321	2)
RC78WP	B4321	2)
RC78WYP11	B4321	2)
RC78WYP15	B4321	2)
RC78YCC15	B4321	2)
RM77N	B8124	1)
RM77PP	B8124	1)
RM79F	B8124	1)
RM82WPCC	B8124	1)
RM85G	B8124	1)
RN79G	B4321	1)/(2)
RN79G1	B4321	1)/(2)
RN79PYP17	B4321	1)/(2)
RN79PYP25	B4321	1)/(2)
RW77N	B7424	1)
RW77PP	B7424	1)
RW78N	B7324	1)
RW80N	B7224	1)
RW80PP	B7224	1)
RW82P	B7224	1)
RW83F	B7224	1)
W10	B7224	1)
W14	B7224	1)
W16Y	B7224	1)
W18	B7324	1)
W20	B7224	1)
W77N	B7424	1)
W80N	B7224	1)
W85N	B7224	1)
W89D	B7224	1)
W95D	B7224	1)

DENSO®	MOTORTECH	NOTE
GE3-1	B4321	1)/(2)
GE3-5	B4321	1)/(2)
GI3-1	B8324	1)
GI3-3	B8324	1)
GI3-5	B8324	1)
GK3-1	B4321	2)
GK3-5	B4321	2)
GL3-1	B8324	
GL3-3	B8324	
GL3-5	B8324	
GT3-1	B8124	1)

GATEWAY®	MOTORTECH	NOTE
1175112	B8324	1)
1176112	B8324	1)
1177012	B8324	1)
1177512	B8324	1)
1177812	B8324	1)
2178315	B4321	2)
2178317	B4321	2)
2178321	B4321	2)
3014115	B8124	1)
7177115	B8124	
7177315	B8124	
8179215	B4321	2)
8179515	B4321	2)
9018025	B7324	1)
9077112	B7424	1)
9077115	B7424	1)
9080113	B7224	1)
9080120	B7224	1)
9085113	B7224	1)
9085120	B7224	1)
9089525	B7224	1)
9177112	B7424	1)
9177115	B7424	1)

1) Due to divergent hex sizes, use of suitable spark plug socket is necessary for installation of MHP-Plug.

2) MHP-Plug requires use of special spark plug lead due to longer ceramic insulator.

## Cross References

GATEWAY®	MOTORTECH	NOTE
9178112	B7324	1)
9180112	B7224	1)
9180115	B7224	1)

GUASCOR®	MOTORTECH	NOTE
76.64.291	B8324	1)
76.64.292	B8324	1)
76.64.375	B8324	1)

MAN®	MOTORTECH	NOTE
51.25923-0016	B4321	1)/(2)
51.25923-0046	B4321	1)/(2)
51.25923-0050	B4321	1)/(2)
51.25923-0051	B4321	1)/(2)
51.25923-0052	B4321	1)/(2)
51.25923-0054	B4321	1)/(2)

MWM®/DEUTZ®	MOTORTECH	NOTE
0422 9132	B4321	
0426 9126	B4321	
1230 1188	B8324	
1230 1248	B8324	
1242 0290	B8324	
1242 0480	B8324	

STITT®	MOTORTECH	NOTE
807	B8124	1)
827	B8124	1)
407XL	B4321	2)
8ME	B8124	1)
R107	B7224	1)
R197	B7224	1)
R407XL	B4321	1)/(2)
R707	B7224	1)
R707	B7424	1)
R717	B7324	1)
R807	B8124	1)
RL807LL	B8324	1)

WAUKESHA®	MOTORTECH	NOTE
69919	B8324	1)
60999F	B8124	1)
69919A	B8324	1)
69919C	B8324	1)
69919D	B8324	1)

1) Due to divergent hex sizes, use of suitable spark plug socket is necessary for installation of MHP-Plug.

2) MHP-Plug requires use of special spark plug lead due to longer ceramic insulator.

## Accessories for MHP-Plugs

### Spark Plug Gap Setting Tool

The simple-to-use tool for setting the spark plug electrode gap is hand-operated and does not need to be additionally mounted on a work-bench. The optionally available accessory components allow a custom-configuration to most commonly used spark plug types in the industry. The perfect tool for a professional job on-site in a material-conserving manner.



- P/N 07.98.120-14** Basic kit for spark plugs with M14x1.25 thread
- P/N 07.98.120-18** Basic kit for spark plugs with M18x1.5 thread
- P/N 07.98.120-78** Basic kit for spark plugs with M22x1.5 and 7/8-18 thread
- P/N 07.98.122-A** Accessory kit for J-type spark plugs

### Extended Barrel Spark Plug Sockets

Installing spark plugs can be a pain. The extended barrel spark plug socket (available up to 36 in. length) has strong magnets incorporated that hold the spark plug when being installed in a deep spark plug well.

- P/N 07.99.022-4-L** Magnetic spark plug sockets for 13/16 in. (20.8 mm) hex, 1/2 in. drive
- P/N 07.99.022-5-L** Magnetic spark plug sockets for 5/8 in. (16.0 mm) hex, 1/2 in. drive



### Torque Wrench

When installing spark plugs, always ensure that you comply with the specifications defined by the spark plug or engine manufacturer. The torque wrench fits MOTORTECH magnetic spark plugs sockets and ensures a “stress-free” installation for the spark plug in compliance with the manufacturer’s torque specifications.

- P/N 07.98.065** Torque wrench, 1/2 in. drive



### Spark Plug Cleaning Kit

Deposits and residue form on the spark plug during operation. The MOTORTECH spark plug cleaning kit allows these to be easily and carefully removed in the electrode area and the thread during regular maintenance intervals.



- P/N 44.01.023** Spark plug cleaning kit

### Spark Plug Gaskets

Spark plug gaskets just once provide an optimal seal between spark plug and seat. Spark plugs must be installed with a new gasket after every service in order to ensure the best possible seal in future operation.



- P/N 02.85.015-100** Spark plug gaskets for M14x1.25 thread, pack of 100 pcs.
- P/N 02.85.016-100** Spark plug gaskets for M18x1.5 thread, pack of 100 pcs.
- P/N 02.85.017-100** Spark plug gaskets for M22x1.5 and 7/8-18 thread, pack of 100 pcs.

### Thread Lubricant

This lubricant is non-metallic and non-conductive. Guarantees easy spark plug removal and prevents thread damage. Also for use with seat & thread reconditioner.



- P/N 07.98.718** Thread lubricant, 4 oz/115 g



-  Headquarter
-  Office
-  Sales Partner

 **MOTORTECH GmbH**  
Hogrevestr. 21-23  
29223 Celle  
Germany  
Phone: +49 (5141) 93 99 0  
Fax: +49 (5141) 93 99 99  
[www.motortech.de](http://www.motortech.de)  
[motortech@motortech.de](mailto:motortech@motortech.de)

 **MOTORTECH Americas, LLC**  
1400 Dealers Avenue, Suite A  
New Orleans, LA 70123  
USA  
Phone: +1 (504) 355 4212  
Fax: +1 (504) 355 4217  
[www.motortechamericas.com](http://www.motortechamericas.com)  
[info@motortechamericas.com](mailto:info@motortechamericas.com)

 **MOTORTECH Shanghai Co. Ltd.**  
Room 1018 Enterprise Square,  
No. 228 Meiyuan Road,  
Zhabei District, 200070 Shanghai  
China  
Phone: +86 (21) 6380 7338  
[www.motortechshanghai.com](http://www.motortechshanghai.com)  
[info@motortechshanghai.com](mailto:info@motortechshanghai.com)

Distributed by:

#### Copyright

The copyright for all materials used in this MOTORTECH publication is reserved. Any kind of duplication or use of objects such as pictures or texts in other electronic or printed publications without approval by MOTORTECH is not permitted.

#### Trademark Information

MOTORTECH products and the MOTORTECH logo are registered and/or common law trademarks of MOTORTECH Holding GmbH.

All OEM names and part numbers shown are for reference purposes only. All trademarks, logos and symbols used or shown in this MOTORTECH publication are exclusive objects to the right of their owners and are used for reference purposes only.