

# VARIFUEL<sub>2</sub> – AIR/FUEL RATIO MIXER

## OPERATING MANUAL



**VariFuel<sub>2</sub>**   
AIR/FUEL RATIO MIXER

### Copyright

© Copyright 2011 MOTORTECH GmbH. All rights reserved.

Distribution and reproduction of this publication or parts thereof, regardless of the specific purpose and form, are not permissible without express written approval by MOTORTECH. Information contained in this publication may be changed without prior notice.

### Trademarks

All trademarks and logos displayed or used in this publication are the property of the respective entitled party.

# TABLE OF CONTENTS

<b>1 General Information</b> .....	<b>5</b>
1.1 What Is the Purpose of this Operating Manual? .....	5
1.2 Who Is this Operating Manual Targeted to? .....	5
1.3 What Symbols Are Used in the Operating Manual? .....	5
1.4 What Abbreviations / Acronyms Are Used in the Operating Manual? .....	6
<b>2 Safety Instructions</b> .....	<b>7</b>
2.1 General Safety Instructions .....	7
2.2 Electrostatic Discharge Hazards .....	8
2.3 Special Safety Instructions for the Device .....	8
2.4 Proper Disposal.....	9
<b>3 Intended Use</b> .....	<b>10</b>
3.1 Function Description .....	10
3.2 Applications.....	13
<b>4 Product Description</b> .....	<b>14</b>
4.1 Technical Data .....	14
4.1.1 Certifications .....	14
4.1.2 Mechanical Data .....	15
4.1.3 Product Identification – Labeling on the Device .....	15
4.1.4 Electrical Data.....	15
4.1.5 Overview Drawings.....	16
<b>5 Installation Instructions</b> .....	<b>19</b>
5.1 Unpacking .....	19
5.2 Assembly .....	19
<b>6 Operation</b> .....	<b>23</b>
6.1 Start-up .....	23
<b>7 Disturbances</b> .....	<b>24</b>
7.1 Possible Faults .....	24
7.2 Customer Service Information .....	24
7.3 Returning Equipment for Repair / Inspection .....	25
7.4 Instructions for Packaging the Equipment .....	25

# TABLE OF CONTENTS

<b>8 Maintenance</b> .....	<b>26</b>
<b>8.1 Maintenance Instructions</b> .....	<b>26</b>
<b>8.2 Spare Parts and Accessories</b> .....	<b>26</b>
<b>9 Index</b> .....	<b>27</b>

# 1 GENERAL INFORMATION

Prior to use, read this operating manual carefully and familiarize yourself with the product. The installation and start-up should not be performed without reading and understanding this document. Keep this manual readily available so that you can reference it as needed.

## 1.1 What Is the Purpose of this Operating Manual?

This manual serves as an aid for the installation and operation of the product and supports the technical staff with all operating and maintenance tasks to be performed. Furthermore, this manual is aimed at preventing dangers to life and health of the user and third parties.

## 1.2 Who Is this Operating Manual Targeted to?

The operating manual provides a code of conduct for personnel tasked with the set-up, operation, maintenance, and repair of gas engines. A certain level of technical knowledge with respect to the operation of gas engines and basic knowledge of electronic ignition systems are necessary. Persons who are merely authorized to operate the gas engine shall be trained by the operating company and shall be expressly instructed concerning potential hazards.

## 1.3 What Symbols Are Used in the Operating Manual?

The following symbols are used in this manual and shall be observed:



### Example

This symbol indicates examples that illustrate the necessary steps and techniques for you. Furthermore, the examples provide you with supplemental information to increase your knowledge.



### Notice

This symbol indicates important information for the operator. Observe these instructions. Additionally, this symbol is used for overviews that provide you with a summary of the required work steps.



### Warning

This symbol indicates warnings of potential risks of damage or danger to health. Read these warning notices carefully and take the stated safety precautions.

# 1 GENERAL INFORMATION



## Danger

This symbol warns of danger to life, especially due to high voltage. Read these warning notices carefully and take the stated safety precautions.

## 1.4 What Abbreviations / Acronyms Are Used in the Operating Manual?

In the manual, the following abbreviations / acronyms are used.

Abb.	Term	Description	Explanation
CE	Conformité Européenne	Documents compliance with EU directives	Mark based on EU legislation for certain products in conjunction with product safety
CSA	Canadian Standards Association	Canadian Standards Association	Organization that defines standards, inspects products for safety compliance, and issues pertinent certifications.
EMC	Electromagnetic compatibility		Compatibility of electrical or electronic equipment items with their surroundings.
ESD	Electrostatic Discharge	Electrostatic Discharge	

## 2 SAFETY INSTRUCTIONS

### 2.1 General Safety Instructions

The following safety instructions must be observed in the environment in which the equipment is operated.



#### **High voltage! Danger to life!**

While the engine is running, especially the area around the ignition system holds the risk of danger due to high voltage. Therefore, the following parts must not be touched or removed:

- ignition coils and boots
- wires of the high voltage circuit
- connectors of the input / output wiring
- pickups and their wiring

MOTORTECH equipment is manufactured as state of the art and therefore safe and reliable to operate. Nonetheless, the equipment may cause danger or damage if the following instructions are disregarded:

- The gas engine must be operated by trained and authorized personnel, only.
- Operate the equipment only within the parameters specified in the technical data.
- Use the equipment correctly and for its intended use only.
- Never apply force.
- For all work such as installation, conversion, adaptation, maintenance, and repair, all equipment must be disconnected from the mains and secured against unintentional reactivation.
- Perform only such maintenance and repair work as is described in this operating manual, and follow the instructions described while working. For maintenance of the equipment, only use spare parts supplied by MOTORTECH. Further work must only be performed by personnel authorized by MOTORTECH. Non-compliance with the instructions will void any warranties for the proper function of the equipment as well as the responsibility for the validity of the certifications.
- Safety devices must not be dismantled or disabled.
- Avoid all activities that can impair the function of the equipment.
- Operate the equipment only while it is in proper condition.
- Investigate all changes detected while operating the gas engine or ignition system.
- Ensure compliance with all directives and regulations applicable to the operation of your system, including such not expressly stated herein.
- Always ensure adequate ventilation of the engine compartment.
- Ensure a safe position at the gas engine.

## 2 SAFETY INSTRUCTIONS

### 2.2 Electrostatic Discharge Hazards

Electronic equipment is sensitive to static electricity. To protect these components from damage caused by static electricity, special precautions must be taken to minimize or prevent electrostatic discharge.

Observe these safety precautions while you work with the equipment or in its vicinity.

- Before performing maintenance or repair work, ensure that the static electricity inherent to your body is discharged.
- Do not wear clothing made from synthetic materials to prevent static electricity from building up. Your clothing should therefore be made of cotton or cotton mix materials.
- Keep plastics such as vinyl and styrofoam materials as far away from the control system, the modules, and the work environment as possible.
- Do not remove the circuit boards from the housing of the device.

### 2.3 Special Safety Instructions for the Device



#### **Explosion hazard!**

While the system is live, do not remove any connectors unless the absence of potentially explosive atmospheres around the system is ensured.



#### **Explosion hazard!**

If the system is not entirely tight and sealed, gas may escape and result in explosion hazard. Upon completion of all assembly works, please always check the system's tightness. In this case, please make sure the test port is closed.

All works involving gas-carrying parts must be executed by trained personnel only.



#### **Operational safety!**

All screws of the connectors must be adequately tightened.



#### **Risk of damage due to electrostatic discharge**

The VariStep stepper motor card may only be installed by specialized personnel which has been trained in handling ESD sensitive components, and with due regard to relevant ESD Standards. It must be installed within a control cabinet and it is necessary to comply with the ESD standard DIN EN 61340-5-1; VDE 0300-5-1:2008-07.

Damages caused by electrostatic discharge are not covered by the guarantee.



#### **Risk of burning!**

The surfaces of the system may heat up to high temperatures.

## **2.4 Proper Disposal**

After the expiration of its service life, MOTORTECH equipment can be disposed of with other commercial waste, or it may be returned to MOTORTECH. We will then ensure its environmentally friendly disposal.

## 3 INTENDED USE

### 3.1 Function Description

All graphics used in the functional description represent an example of a VariFuel2 series 140. The exact position of the individual parts varies slightly with other series. For the detailed design and exact dimensions please refer to section *Overview Drawings* on page 16.

#### Basic Design

The main task of the gas mixer is to mix the fuel (gas) and the air so that an optimal combustion is ensured within the gas engine. Here, the decisive optimization parameters are a high degree of efficiency and low emissions (always compliant with relevant regulations).

In the VariFuel2 gas and air are mixed based on the Venturi principle. Based on the suction pressure of the engine, the air is sucked in through the air inlet [a] into the Venturi nozzle. At the most narrow place there will be an underpressure which will suck in the gas through the gas inlet [b]. In this way, both the gas and the air are mixed and output at the mixture outlet [c]. Based on different design sizes and different flowbodies in the Venturi nozzle, it is possible to achieve various volume flows.

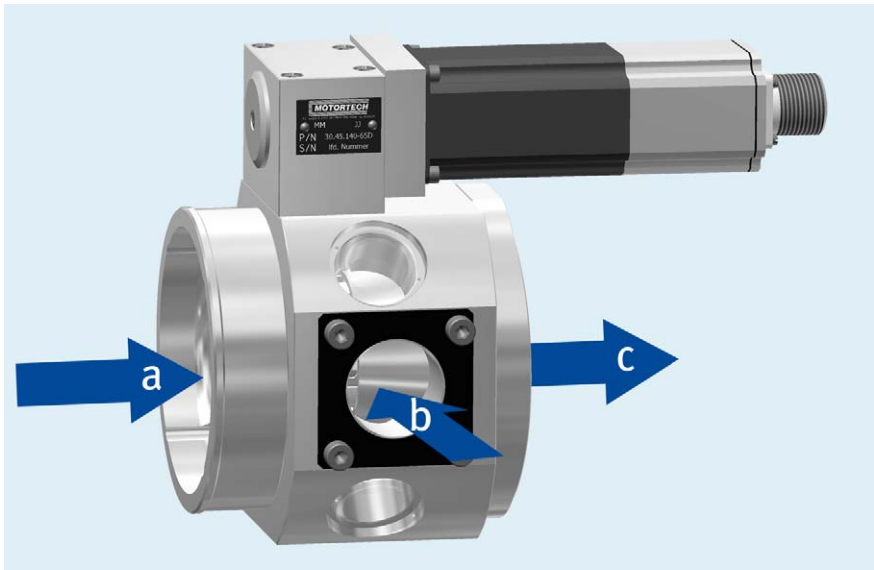

## Designation of Components

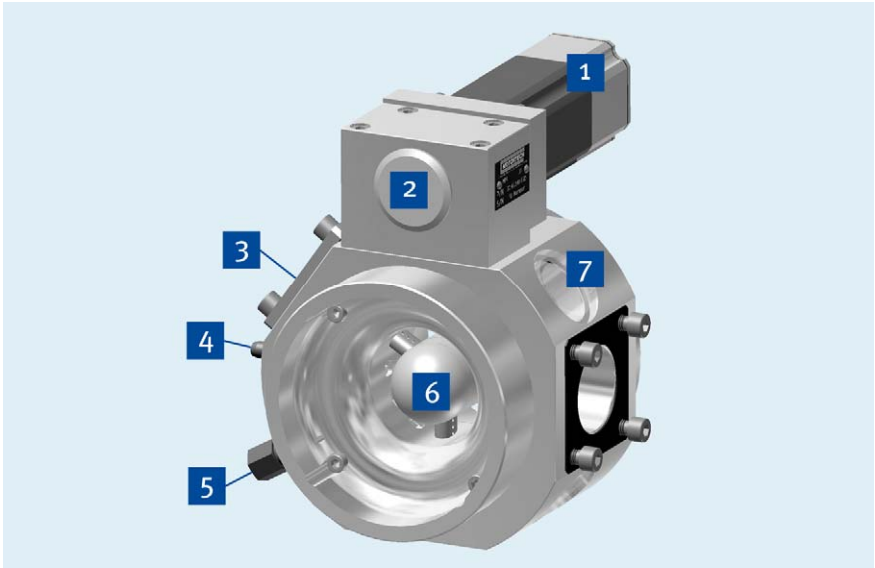

Item No.	Description
1	Stepper motor
2	Maintenance cap
3	Alternative gas connection
4	Test port
5	Port for control cable
6	Flowbody
7	Inspection glass

## 3 INTENDED USE

### Regulation of the Air/Fuel Mixture

The fuel (gas) is routed into the nozzle using the adjustable openings in a fuel ring [a]. The openings of the fuel ring are adjusted using a drive belt [b] depending on the relevant VariFuelz type either manually or, normally, via a stepper motor. The stepper motor can be controlled using a stepper motor card. This can process the signals of a master control.

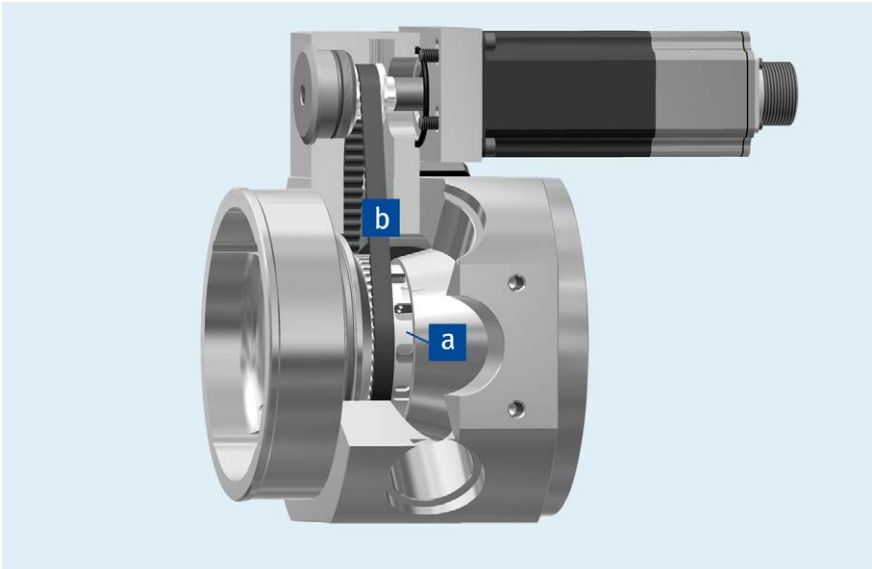

### 3.2 Applications

VariFuel2 can be used with gas-Otto-engines. The following substances are approved as fuels:

- Natural gas H according to DVGW Sheet 260
- Regenerative gases according to DVGW work sheet 262
- additional special gases may be used upon approval  
(there may be restrictions in the case of excessive humidity or impurities in the gas such as tar)

With the correct design selected it is possible to add a fuel gas of 3.0 to 10.0 kWh/m<sup>3</sup><sub>N</sub> to the constant air volume flow (with the same mixer).

Mixing the air and fuel with the VariFuel2 must be done with the same pressure, therefore it is necessary to use a zero pressure regulator within the gas train.

The VariFuel2 can mix up to two gases with air. With lean gas applications (such as wood or landfill gas) it is possible to interconnect two VariFuel2 mixer to achieve a mixing ratio of < 1:4.

Any use other than the one described in the operating manual shall be considered improper use and will result in the voiding of all warranties.

## 4 PRODUCT DESCRIPTION

### 4.1 Technical Data

#### 4.1.1 Certifications

## CE DECLARATION OF CONFORMITY

The company:

**MOTORTECH GmbH**  
**Hogrevestrasse 21-23**  
**29223 Celle**

declares that the products:

**VariFuel2**

purpose:

**use with gas otto engines**

is in compliance with the specifications of the following EU directives:

**EMC Directive 2004/108/EC**  
**Machinery Directive 2006/42/EC**

The identification code of the product is:

**P/N 30.45.100-50x**  
**P/N 30.45.140-65x**  
**P/N 30.45.200-100x**

This declaration is delivered by:

Name: Florian Virchow

Position within the company: Managing  
director

Celle, dated 12/01/2010

Place, date



Legally binding signature

### 4.1.2 Mechanical Data

The devices of the VariFuelz series have the following mechanical characteristics.

Feature	Value
Dimensions	See chapter <i>Overview Drawings</i> on page 16.
Weight	<p><b>100 series</b> with stepper motor: 3,7 kg (8.16 lbs) without stepper motor: 2,6 kg (5.73 lbs)</p> <p><b>140 series</b> with stepper motor: 6,2 kg (13.67 lbs) without stepper motor: 5,1 kg (11.24 lbs)</p> <p><b>200 series</b> with stepper motor: 9,2 kg (20.28 lbs) without stepper motor: 8,0 kg (17.64 lbs)</p>
Shape of device	See chapter <i>Overview Drawings</i> on page 16.

### 4.1.3 Product Identification – Labeling on the Device



Abb.	Meaning
MM	Month of production
YY	Year of production
P/N	Part number of device
S/N	Serial number of device

### 4.1.4 Electrical Data

For electrical data of the stepper motor's control unit please refer to the operating manual of the VariStep stepper motor card.

# 4 PRODUCT DESCRIPTION

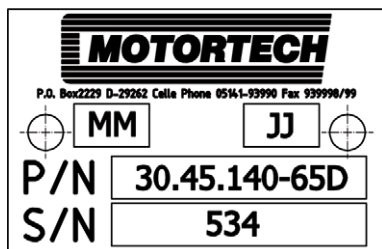
## 4.1.5 Overview Drawings

### Dimensions 100 series

#### Model with stepper motor adjustment

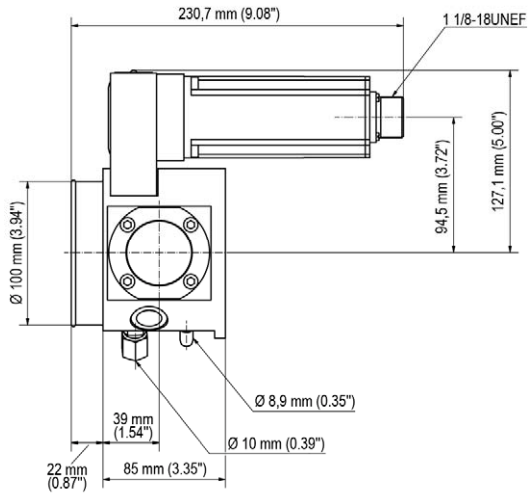
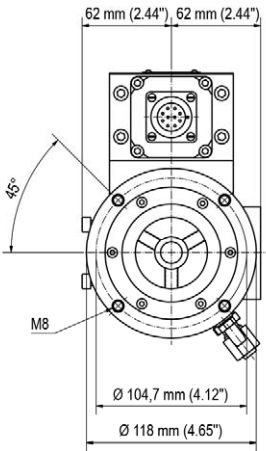

#### Model with manual adjustment

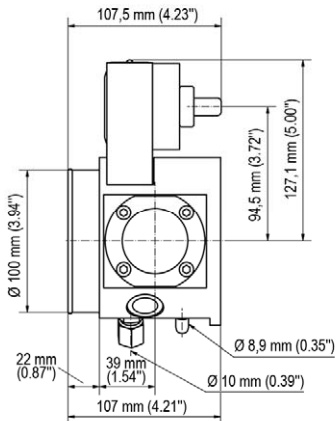
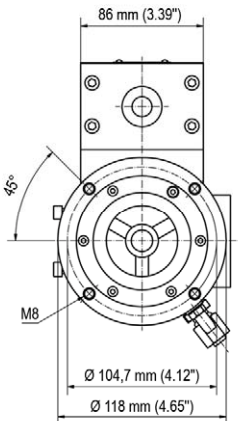

### Dimensions 140 series

#### Model with stepper motor adjustment

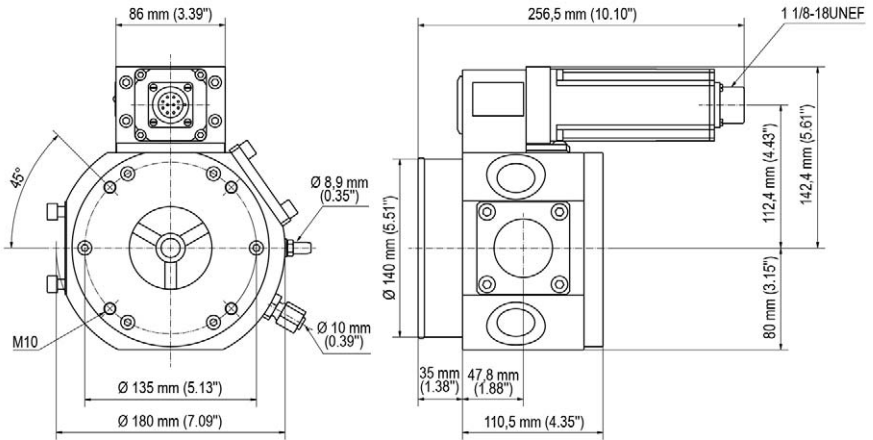

#### Model with manual adjustment

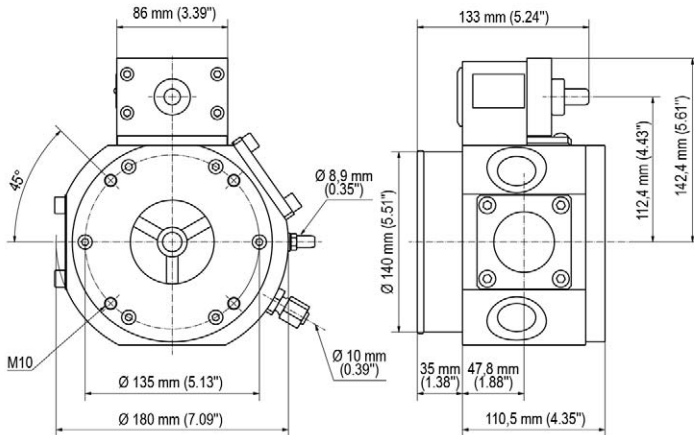

# 4 PRODUCT DESCRIPTION

## Dimensions 200 series

### Model with stepper motor adjustment

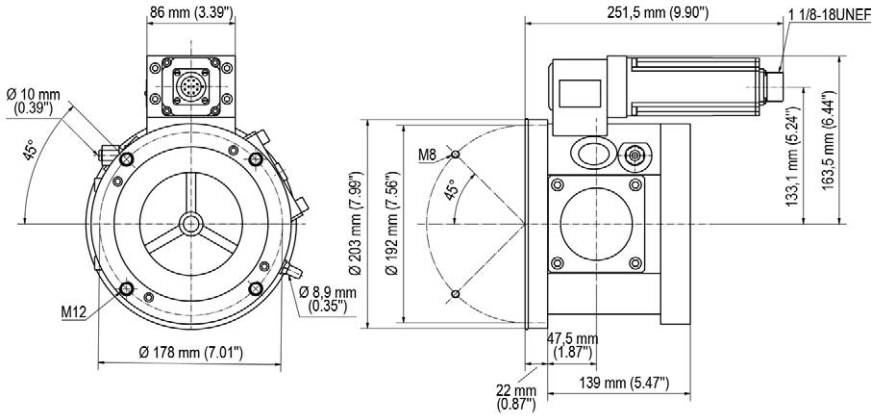

### Model with manual adjustment

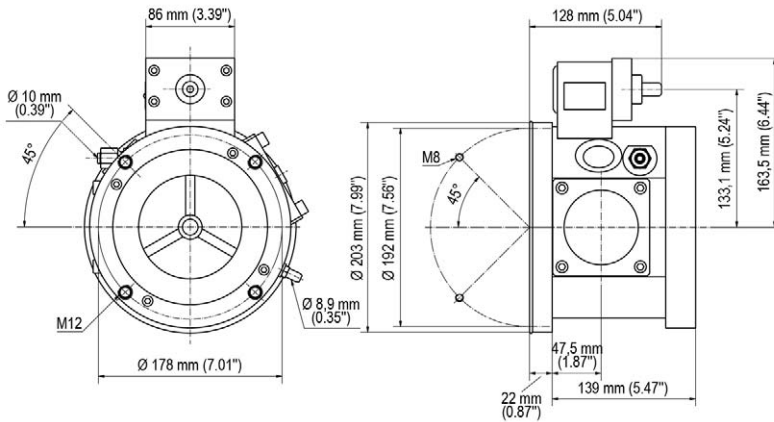

## 5 INSTALLATION INSTRUCTIONS

### 5.1 Unpacking

Unpack the equipment, taking care not to damage it, and ensure that the operating manual is always stored with the equipment and easily accessible. Check the contents for completeness and verify that the controller type meets your application requirements.



#### **Risk of damage due to electrostatic discharge**

The VariStep stepper motor card may only be installed by specialized personnel which has been trained in handling ESD sensitive components, and with due regard to relevant ESD Standards. It must be installed within a control cabinet and it is necessary to comply with the ESD standard DIN EN 61340-5-1; VDE 0300-5-1:2008-07.

Damages caused by electrostatic discharge are not covered by the guarantee.

### Scope of Supply

The supply scope of the VariFuel2 consists of the following components:

- VariFuel2 gas mixer
- Operating Manual

### Accessory

- Flowbody
- Optional: Adaptors for gas inlet and mixture outlet
- Wiring harness for the connection between VariFuel2 and stepper motor card (not required with manual adjustment)
- VariStep stepper motor card incl. CD-ROM and USB interface cable (not required with manual adjustment)

### 5.2 Assembly

The following steps must always be carried out and are specified in more detail in the following:

- Install flowbody
- Install VariFuel2 into intake section (air and gas inlet plus mixture outlet)
- Connect stepper motor card

# 5 INSTALLATION INSTRUCTIONS

## Install Flowbody

To install or replace the flowbody, free access must be provided at the VariFuelz both on the air inlet and on the mixture outlet.

1. At first, please completely disassemble the flowbody by unscrewing the nut and disconnecting the two body halves.
2. Then, mount the round half by sliding it over the center ring of the nozzle on the air inlet. Please note that the smallest flowbody ( $\varnothing 23 \text{ mm}/0.9''$ ) cannot be put on the center ring of the nozzle but must be put in front of it.
3. Now, please install the second half of the flowbody (on the mixture outlet side) over the screw of the first half and the center ring of the nozzle.
4. Tighten the screw using the washer and the nut.

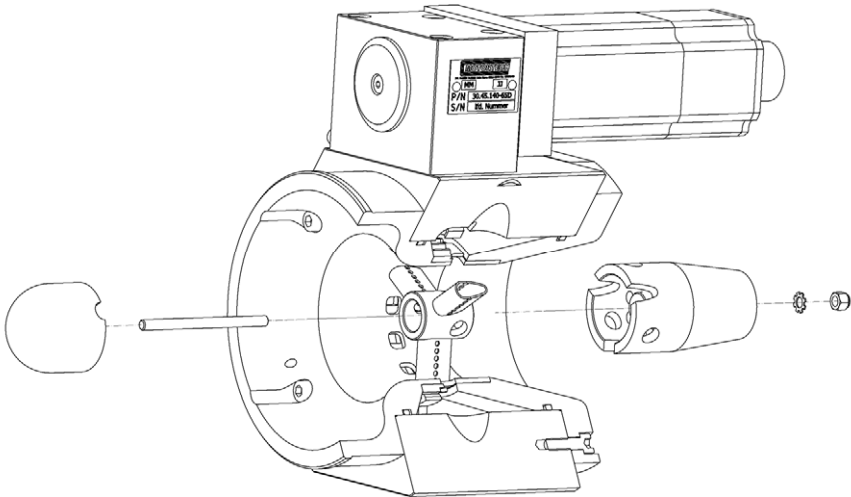

### Explosion hazard!

If the system is not entirely tight and sealed, the combustible gas mixture may escape and result in explosion hazard. Therefore, all ports and connections must be gas-tight. Always use suitable sealing and connecting material.

### Install VariFuel2 into Intake Section

The mounting position of the VariFuel2 on the intake section of the engine depends of the overall arrangement. Generally, you need to connect the following ports:

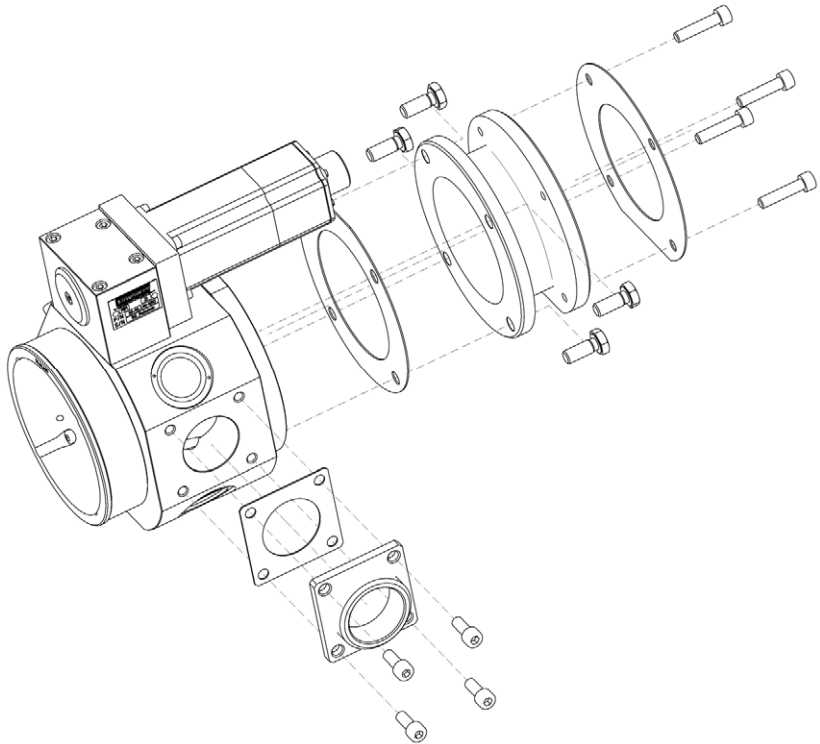

- **Air inlet**  
Hose connection (such as with clamp, seal/gasket and counter flange).
- **Gas inlet**  
Connection of a flexible gas line via an installation flange. It is particularly important that the gas line is flexible if the gas mixer is rigidly coupled with the engine. For the gas connection there is an alternative port on the opposite side of the VariFuel2. If required, it is possible to modify the relevant cover. If two different gas qualities are used, both gas inlet ports can be used. In this case you need to order another adapter.

## 5 INSTALLATION INSTRUCTIONS

- **Mixture outlet**

Connection via a hole circle for engine-specific fastening flange (available with clamp, sealing and counter flange) to weld on a pipe.

- **Installation options**

The VariFuel2 must be mounted without tension and not overhead, i.e. with the stepper motor downwards. Beyond that, you can freely decide about the installation position. However, the inspection glass should be freely accessible (not covered by a pipe or something else). Also, the maintenance cap should be easily accessible to ensure you can check and adjust the belt tension. For the purpose of the installation, on the underside of the device there are four M6 tap holes with a planar contact area.

### Connecting the control unit

The connection of the control unit of the stepper motor is described in the operating manual of the VariStep stepper motor card.

## 6 OPERATION

### 6.1 Start-up



#### Explosion hazard!

If the system is not entirely tight and sealed, the combustible gas mixture may escape and result in explosion hazard. Upon completion of your works, please make sure that you close the test port on the VariFuel2.

#### Basic Settings of the System

With an ideal design, the VariFuel2 is operated in a range between 15 and 70% of the fuel ring's opening. In this way the prescribed emission values should be complied with nominal load.

#### Problems when starting

Often the gas engine's problem is its starting behavior. With the starting speed the air speed in the mixer is very low, which will cause very low suction pressure at the gas inlet. Only with the zero pressure regulator correctly adjusted, the engine will start to run. For this, it is necessary to adjust the zero pressure regulator to a slight overpressure (approx. 0.5 mbar with starting speed).

#### Any other problems

With the prescribed emissions, the engine does not reach its nominal output. The following scenarios might be possible:

##### Scenario1:

- the opening of the fuel ring is in the range between 15 and 70%
- the nominal output is reached by enriching the mixture
- on the test port of the VariFuel2 an underpressure larger 30 mbar is measured

In this case, it is necessary to increase the air supply. This can be achieved based on the following measures:

- Check the underpressure in the air intake line (standard value: -5 to -25 mbar)
- install smaller flowbody

##### Scenario2:

- the opening of the fuel ring is  $> 95\%$
- the nominal output is not even reached by enriching the mixture
- on the test port of the VariFuel2 an underpressure smaller 60 mbar is measured

In this case, it is necessary to increase the gas supply. This can be achieved based on the following measure:

- install larger flowbody

# 7 DISTURBANCES

## 7.1 Possible Faults



### Explosion hazard!

If the system is not entirely tight and sealed, the combustible gas mixture may escape and result in explosion hazard.

The device's tightness will be checked and guaranteed by MOTORTECH after production. If the device is opened by the customer for installation or maintenance purposes, the customer is responsible to restore the system's tightness. If the customer cannot guarantee this, the device must not be opened and must be replaced and returned to MOTORTECH to remedy any failures.

### Fuel Ring sticks

If the fuel ring does not respond to the signals of the control unit, this can have various causes:

- **electrical causes**  
Please check the wiring of the control unit and the stepper motor.
- **mechanical causes**  
The residues in the gas may cause deposits between the fuel ring and the sliding surface. This increases the belt tension until the fuel ring does not move any more. The belt tension needs to be checked and, if necessary, drive belts and the fuel ring need to be changed. In the case of questions, please contact your MOTORTECH contact person.

## 7.2 Customer Service Information

You can reach our customer service during business hours by phone, fax, or e-mail at:

- Tel.           +49 5141 9399 0  
Fax            +49 5141 9399 99  
E-mail        servicemail@motortech.de

### 7.3 Returning Equipment for Repair / Inspection

Enclose an insert containing the following information when returning the equipment for repair and inspection:

- Name of operating company
- Name and location at which the equipment is installed
- Name and phone number of a contact person
- Engine type
- Part and serial numbers of the device
- Description of the defect/error
- Instructions concerning the desired type of repair/inspection

Providing this information will ensure the speedy and smooth processing of your repair order.

Send the equipment to one of the two addresses below or to the nearest MOTORTECH representative:

#### MOTORTECH GmbH

Hogrevestrasse 21-23  
29223 Celle

Germany

Tel. +49 51 41 - 93 99 0  
Fax +49 51 41 - 93 99 98

[www.motortech.de](http://www.motortech.de)  
[motortech@motortech.de](mailto:motortech@motortech.de)

#### MOTORTECH Americas

1400 Dealers Avenue  
New Orleans, LA 70123

USA

Tel. +1 504 355 4212  
Fax +1 504 355 4217

[www.motortechamericas.com](http://www.motortechamericas.com)  
[info@motortechamericas.com](mailto:info@motortechamericas.com)

### 7.4 Instructions for Packaging the Equipment

For return shipment, equipment should be packaged as follows:

- Use packaging material that does not damage the equipment surfaces.
- Wrap the equipment with sturdy materials and stabilize it inside the packaging.
- Use sturdy adhesive film to seal the packaging.
- The stepper motor card must be packed within a ESD-protective foil.

# 8 MAINTENANCE

## 8.1 Maintenance Instructions

Please observe the following maintenance note:

- All maintenance works which require to open the VariFuel2 (such as adjusting the fuel ring) must only be carried out by personnel trained by MOTORTECH.
- For replacing any spare parts (such as drive belt, fuel ring) the device must be returned to MOTORTECH. For the time of the repair, MOTORTECH will provide an exchange unit.



### **Explosion hazard!**

If the system is not entirely tight and sealed, the combustible gas mixture may escape and result in explosion hazard.

The device's tightness will be checked and guaranteed by MOTORTECH after production. If the device is opened by the customer for installation or maintenance purposes, the customer is responsible to restore the system's tightness. If the customer cannot guarantee this, the device must not be opened and must be replaced and returned to MOTORTECH to remedy any failures.

## 8.2 Spare Parts and Accessories

For spare parts and accessories, please refer to our current Product Guide, which is available to download from the Internet at [www.motortech.de](http://www.motortech.de).

## 9 INDEX

<b>A</b>	
Article Number .....	15
Assembly .....	19
<b>D</b>	
Declaration of Conformity .....	14
Dimensions	
VariFuel2.....	16
<b>E</b>	
Error .....	24
<b>F</b>	
Flowbody	
Install .....	19
<b>I</b>	
Installation .....	19
<b>M</b>	
Mechanical Data	
VariFuel2.....	15
MOTORTECH	
Address .....	25
<b>R</b>	
Regulations	
VariFuel2.....	14
Repair.....	25
Return Shipment .....	25
<b>S</b>	
Safety Instructions .....	7
Scope of Supply .....	19
Serial Number .....	15
Start-up .....	23
<b>V</b>	
VariFuel2	
Application Range.....	13
Design .....	10
Dimensions .....	16
Disposal.....	9
Electrical Data .....	15
Function .....	10
Mechanical Data.....	15

# WE UPGRADE GAS ENGINES

## Original MOTORTECH Accessories for Stationary Gas Engines

As a supplier, MOTORTECH develops, manufactures and distributes accessories as well as spare and wearing parts for nearly all kind of stationary gas engines worldwide: Ignition control and monitoring, industrial spark plugs and high tension leads, wiring systems and gas regulation – from detonation to speed control and complete gas engine management. On-site support and special training courses complete our service.



**MOTORTECH GmbH**  
Hogrevestr. 21-23  
29223 Celle  
Phone: +49 5141 9399 0  
Fax: +49 5141 9399 99  
[www.motortech.de](http://www.motortech.de)  
[motortech@motortech.de](mailto:motortech@motortech.de)

**MOTORTECH AMERICAS LLC**  
1400 Dealers Avenue  
New Orleans, LA 70123  
Phone: +1 504 355 4212  
Fax: +1 504 355 4217  
[www.motortechamericas.com](http://www.motortechamericas.com)  
[info@motortechamericas.com](mailto:info@motortechamericas.com)